



Therma-Flow[®]

Freeze-Protected Shower and Eyewash

Installation, Operation, and Maintenance Manual

09900001

Revision "K" 10/27/2015

PAGE LEFT BLANK INTENTIONALLY

TABLE OF CONTENTS

SECTION I	GENERAL DESCRIPTION	Page 3
SECTION II	INSTALLATION INSTRUCTIONS	Page 5
SECTION III	TEST & INSPECTION PROCEDURE	Page 7
SECTION IV	MAINTENANCE AND REPAIR INSTRUCTIONS	Page 9
SECTION V	TROUBLESHOOTING	Page 13
SECTION VI	RECOMMENDED SPARE PARTS.....	Page 15
SECTION VII	DRAWINGS AND DIAGRAMS	Page 19
	THERMA-FLOW® INSPECTION REPORT	Page 45

WARRANTY:

WITH RESPECT TO Therma-Flow® (THE "EQUIPMENT") ENCON HEREBY DISCLAIMS ALL WARRANTIES, EXPRESSED OR IMPLIED, INCLUDING THE IMPLIED WARRANTY OF MERCHANTABILITY AND FITNESS FOR A PARTICULAR PURPOSE, EXCEPT AS HEREAFTER PROVIDED.

ENCON warrants the Equipment to be free of defects in material and workmanship if properly installed, cared for and operated under normal conditions, with competent supervision, and in accordance with **ENCON's** installation, operating and maintenance instructions. With respect to the Equipment, **ENCON's** only obligation under this warranty is to repair or replace such components of the Equipment:

1. As proved defective and **ENCON** is so advised within one year after shipment, and
2. Shall appear to **ENCON's** satisfaction to have been defective in material or workmanship.
3. Encon Safety Products will request completion of a Service Authorization Agreement by an Authorized employee of the customer prior to on site inspection by Encon personnel of the warranty claim.

However, in no event shall **ENCON** be liable under this Warranty unless **ENCON** is provided an opportunity to inspect such material or workmanship and, at its option, allowed to repair or replace such material or workmanship.

No warranty is given in connection with any portion of the Equipment, which is altered or rebuilt without **ENCON's** express written consent.

ENCON shall not be liable for loss, damage, or expense, arising directly, or indirectly, as a consequence of use of the equipment with other products, or from any other cause, other than **ENCON's** obligation to repair or replace defective components of the Equipment as expressly provided in this warranty statement.

THE CUSTOMER'S PURCHASE AND ACCEPTANCE OF THE EQUIPMENT SHALL BE DEEMED TO BE ITS AGREEMENT TO BE BOUND BY THE TERMS AND PROVISIONS OF THIS WARRANTY.

Under no circumstances will ENCON ever be liable for indirect or consequential loss or damage arising out of the ownership or use of the Equipment.

The terms of this Warranty shall apply to any replacement parts installed on, or furnished in connection with the Equipment.

PAGE LEFT BLANK INTENTIONALLY

I. GENERAL DESCRIPTION OF THERMA-FLOW® FREEZE-PROTECTED SHOWER AND EYEWASH

The Therma-Flow® shower and eyewash is an electrically traced freeze protected emergency shower and eyewash. This product is third party certified to meet and/or exceed the American National Standards Institute/International Safety Equipment Association (ANSI/ISEA) Standard Z358.1 for emergency shower and eyewash equipment. The Therma-Flow® shower and eyewash station is protected from freezing by self-limiting heating cable (electric tracing). The specified cable in conjunction with the closed cell insulation maintains the internal shower temperature above 32°F (0°C). The Therma-Flow® shower and eyewash insulation and component parts are encapsulated by ABS covers. These covers are field removable in segments (i.e. eyewash section, shower section, etc. *See Section VII, Figure 3B and Figure 9 for reference*). The field removable covers are provided such that any mechanical or electrical failure can be readily diagnosed and repaired with a minimum of effort, spare parts and down time.

The ABS covers are held together at the flange area of the cover by means of seal strips. Seal strips are held in place by a compression fit. The black seal strips house a segmented neoprene coated aluminum closure band, allowing flexibility and corrosion resistance. The seal strips are adjustable and can be refitted and adjusted as required using a blade screwdriver to open, pliers to compress as necessary. Protrusions (items passing through the removable covers) are sealed with synthetic rubber seals; these seals prevent water, gases, and moving air from entering the dead air space. They are essential components in the success of freeze protection, operation, and longevity of the shower and eyewash equipment.

Therma-Flow® shower and eyewash stations are available in many different model orientations; therefore, a standard model is only a standard to you, the owner. We therefore, offer an installation and maintenance manual addressing general subjects. If you should experience difficulties not mentioned in the following pages, please refer these difficulties to your local authorized Encon agent, or address Encon Safety Products, 6825 West Sam Houston Parkway N., Houston, Texas 77041, Fax: 713-466-1703, Phone: 800-283-6266. Please include the serial number stamped on the floor flange of the equipment.

PAGE LEFT BLANK INTENTIONALLY

II. INSTALLATION INSTRUCTIONS

NOTE: CONSULT N.E.C. OR LOCAL REGULATIONS REGARDING GROUND FAULT INTERRUPTERS (GFI) PRIOR TO ELECTRICAL CONNECTION

Prior to installation close all water supply lines, disconnect and lock out all electrical services.

1. Inspect crate and unit for shipping damage; insure electrical classification is correct. The first three digits of the model number indicate electrical classification as follows:

TF1 and TF2 = NEMA 4.

TF3 and TF4 = Class 1, Division 2, Group B, C, D.

55 = a special unit built to customer specifications.

Visually inspect and compare to drawing for proper electrical classification.

2. The shower and eyewash station should be removed from its crate taking care not to lift by electrical fittings or the eyewash assembly.
3. After matching the shower and eyewash equipment classification with area classification, stand the equipment in the area to be installed. The unit should be rotated (positioned) such that the hazards can be readily identified with the installer standing under the shower.
4. Secure the floor flange by bolting the flange with (4) ½" (12.7 mm) bolts. The unit does not need to be supported by means other than the floor flange and the water inlet connection.
5. With the power disconnected and before the water supply line inlet is connected, ensure that any particulate is flushed out of the piping supply.
6. Connect the shower and eyewash equipment to the potable water supply with a pressure not less than 30 psi (206.8 kPa) dynamic (flowing) or greater than 80 psi (551.58 kPa) dynamic.
7. Install the showerhead. **DO NOT USE THREAD SEAL TAPE!** These fittings are non-pressure-maintaining fittings and require hand tight assembly without the use of sealant or anti-seize compounds. **Sealants may cause stress cracking on ABS parts.**
8. Install the eyewash assembly by placing float-off covers on the eyewash heads and while holding the eyewash on the wye between the heads, screw the assembly clockwise until hand tight and in the correct position. See the sketch attached to eyewash assembly. Hand tight is sufficient. A rubber gasket seals this non-pressure-maintaining fitting. **DO NOT USE THREAD SEAL TAPE!**

CAUTION! CAUTION! CAUTION!
DISCONNECT AND TAG OUT ELECTRICAL SERVICE PRIOR TO CONNECTING SHOWER

9. Do not connect power prior to water connection. Therma-Flow® shower and eyewash stations are designed for two-point electrical connection. A wiring diagram is located in the main junction box. Connect power and ground per wiring instructions. In those installations where flow switches are installed, do not insulate prior to operation test.
10. Test the unit (See Section III).

PAGE LEFT BLANK INTENTIONALLY

III. TEST AND INSPECTION PROCEDURE

TO TEST THE UNIT: See *Therma-Flow® Inspection Report on page 45 for reference.*

1. Check the eyewash flow pattern by inserting the eyewash tester, Encon part number 01110469, into the dual stream eyewash. Stream should meet the pattern design on the tester when lowered not more than 1½" (38.1 mm) from the point of initial contact.
2. To test the shower, open the shower valve and observe the water spray for quality of water (clear) and pattern of water (minimum 20" [508 mm] diameter pattern, 60" [1524 mm] from floor).
3. Additionally, activation devices should be inspected to see that they are securely fastened to the valve stem of the ball valves. Valves should open (go from OFF to ON) in one second or less and should be drip free.
4. Eyewash covers should be present and attached to the eyewash and on the heads preventing debris from entering the eyewash nozzles.
5. ABS covers should be inspected for integrity, closure strips and seals inspected for tightness, if missing or broken, replace as required to maintain thermal integrity of the unit.

NOTE: *THE THREE WAY SELF-DRAINING EYEWASH WILL REQUIRE FROM 30-90 SECONDS TO COMPLETE ITS DRAIN BACK FUNCTION. DRIPPING FROM THE BOTTOM PORT DURING THIS TIME FRAME IS NORMAL. IN FREEZING CONDITIONS DO NOT COVER EYEWASH NOZZLES UNTIL DRAINING IS COMPLETE.*

PAGE LEFT BLANK INTENTIONALLY

IV. MAINTENANCE AND REPAIR INSTRUCTION

The Therma-Flow® shower and eyewash station is built for long life. It contains the highest quality sub-components of their type. Problems that are typically encountered after extended testing and use follow in the Trouble Shooting Guide.

1. Normal maintenance consists of flushing the unit weekly, testing as specified above and recording the test as required in your facility code of practice.
2. During visual inspection, preventative maintenance consists of inspecting closure strips for tightness and ensuring that all grommets are installed over protrusions and in the covers.

NOTE: REQUIRED READING PRIOR TO INSPECTION TO AVOID UNNECESSARY COVER BREAKAGE DURING THE INSPECTION OR REPAIR.

GENERAL INSTRUCTIONS

The units are constructed for field maintenance. Should any problems occur (including freezing), the yellow ABS plastic covers can be removed by pulling the neoprene (black) closure strips away from the flanged edge of the covers. The covers must then be separated at the segment line (gasket sealed at time of manufacture) and removed. Any and all items protruding through the covers must be physically removed from the unit prior to cover removal, which includes eyewash assembly and push plate assembly. Specific attention must be paid in the area of the eyewash.

- A. To Remove Eyewash - **Disconnect Power to Heat Trace Cable** unless tracing is suspect, in which case de-energize after step 9.
1. While holding the eyewash yoke by the wye, turn counter clockwise until the yoke is removed.
 2. With pipe wrench, remove gray PVC nipple and elbow assembly insuring that the horizontal nipple entering the cover through the rubber grommet remains in place. (Nipple will act as a locator for covers during reinstallation procedure). *See Section VII, Figure 1D for reference.*
 3. Remove 9/16" (14.29 mm) self-locking nut on push plate to remove push plate (or hex head bolt on newer models).
 4. Pull black closure strip away from flanged covers, past the segmentation lines, exposing the eyewash assembly covers for removal.

NOTE: BOTTOM FIRST. THE OVERLAY IS REQUIRED TO MAINTAIN A MOISTURE PROOF BARRIER. (SEE SECTION VII, FIGURE 3B)

5. Pull covers down and away from eyewash, over the ball valve extension. Should black grommet drop out of covers reinsert after cover is off shower.
6. With pocket knife or putty knife remove neoprene insulation self-adhering seal strip, being careful to avoid contact with knife and heat trace cable cover.
7. Pull back insulation.

NOTE: IF INSULATION IS REMOVED UNDAMAGED IT MAY BE REUSED.

8. Inspect eyewash tracing for heat output by touch. Energized tracing, water temp < 55°F (12.8°C), should be just warm to the touch. **DE-ENERGIZE PRIOR TO CONTINUING MAINTENANCE.**

IV. (Continued)

9. If valve packing requires adjustment, it may be done at this time.
10. If ball valve requires removal; with knife cut fiberglass bonding tape which holds tracing to valve and pipe, being careful not to cut outer jacketing of tracing.
11. Pull cable (tracing) over the end of the elbow and lay off the pipe, valve can now be removed for inspection. Repair as required. *See Paragraph D of this section.*

B. Re-assembly of Eyewash Section

1. Replace electric tracing cable in reverse order of removal, assuring that the cable does not interfere with the ball valve extension, or the stops on the valve body.
2. Replace fiberglass-bonding tape assuring as much physical contact (cable to pipe) as possible. Do not use electrical or duct tape.
3. Reinstall neoprene insulation and tape insulation closed, such that there are no exposed metal parts.

NOTE: CARE MUST BE TAKEN TO ASSURE THAT INSULATION DOES NOT IMPAIR VALVE CLOSURE BY IMPEDING STOP CONTACT (SEE SECTION VII, FIGURE 3A).

4. Reinstall covers; top first, by sliding one half of the cover up and then over the ball valve extension and eyewash nipple.
5. Reinstall black seal strip on front and back of shower. Seal strip can be adjusted by crimping with pliers if too loose (prior to attachment to covers), or separated if too tight, by inserting screwdriver and opening up seal strip.
6. Reinstall the ball valve extension push plate and locking nut (*Hex Bolt. See Section VII, Figure 3A*).
7. Reinstall eyewash elbow and nipple assembly.
8. Reinstall eyewash wye by hand tightening.

NOTE: THIS IS A NON-PRESSURE CONTAINING PART AND IS SEALED WITH A RUBBER GASKET. HAND TIGHT IS MORE THAN ADEQUATE TO PREVENT LEAKS.

DO NOT USE THREAD SEAL TAPE

- C. Any other area of the shower and eyewash equipment can be inspected utilizing the stepped procedure listed in *Section IV, A&B*.

D. Maintenance of Ball Valves

1. Remove covers, insulation and electric tracing as described in this section.
2. Adjust packing gland by tightening or repack valve as required.
3. Should the valve leak by the seals, remove from piping and disassemble the valve. Inspect seals for debris permeation and ball for scoring. If ball in valve is replaced, replace all material seals with kit part number.

Eyewash Kit - 00011052

IV. (Continued)

Shower Kit - 00011053

Shower Ball Valve - 00011022

Eyewash Ball Valve - 00011059

Drench Hose Ball Valve - 00011044

E. Freeze / Scald Protection Valves

1. Installation

- a. The piping system should be well-flushed before installation of the freeze or scald valves. Particles in the water may obstruct and prevent complete closing of the valves.
- b. Valve will operate in any position; however, the vertical position is required enabling the station to self-drain.
- c. Flow should be in the direction of the arrow shown on the nameplate.
- d. Discharge from valve should be directly to waste without restrictions. (Large diameter open funnels may be used as flow directors.) **Do Not Connect Pipe to Valve Outlet as this may cause Freezing of the Unit Assembly.**
- e. Temperature control point is factory set and sealed. The element is activated by a temperature change of fluid inside the valve body.
- f. Freeze protection valves will begin to open at 40°F (4.4°C), and will be fully open at 35°F (1.7°C). They are direct acting.
- g. Scald protection valves will begin to open at 95°F (35°C) and will be fully open at 105°F (40.6°C). They are reverse acting.

2. Maintenance Troubleshooting

NOTE: DO NOT ATTEMPT TO FORCE VALVE OPEN OR CLEAN WITH POINTED OBJECT AS SCORING OF VALVE SEAT AND DISK WILL CREATE PERMANENT LEAKAGE.

- a. Valves should be inspected each year, and cycled before hot or cold weather sets in.
 - b. Freeze protection valves should be tightly closed at fluid temperature 40°F (4.4°C) and above. Scald protection valves should be tightly closed at fluid temperature of 92°F (33°C) and below (See Section VII, Figure 4 for reference).
- 1) Freeze Protection Valves:
- a) Carefully remove valve from the unit and place it in ice water for 15 to 20 minutes, causing valve to fully open.
 - b) Remove valve from ice water and force compressed air through valve **INLET** for 2 to 3 minutes, to clean valve.
 - c) Place valve in warm water (70-80°F / 21-26.7°C) for 10 to 15 minutes.
 - d) Remove valve from water and force compressed air through valve **INLET**. No passage of air will be an indication that the valve seat has been closed.

IV. (Continued)

- e) With air connected to the valve submerge in water bath checking for bubbles. If valve leaks, repeat steps a. through d.
- f) Should the procedure described in steps a. through e. fail to stop water leakage, the valve should be replaced with a new component.

2) Scald Protection Valves:

- a) Carefully remove valve from the unit and place it in hot water (105°F / 40.6°C or higher) for 15 to 20 minutes.
- b) Remove valve from hot water and force compressed air through valve **INLET** for 2 to 3 minutes, to clean valve.
- c) Place valve in cold water (40-50°F / 4-10°C) for up to 15 minutes.
- d) Remove valve from cold water and force compressed air through valve **INLET**. No passage of air will indicate that the valve seat has closed.
- e) Submerge valve in water bath to check for bubbles. If valve leaks repeat steps a) through d).
- f) Should the procedure described in steps a. through e. fail to prevent leakage, the valve should be replaced with a new component.

F. Thermostat Removal

If continuity test indicates failure, or a 50 - 60°F (10 - 15.5°C) temperature range cannot be induced under field conditions (operating shower with bottom water supply connection or eyewash for top water supply connection). Perform the following steps in thermostat removal (See Section VII, Figure 1E for reference).

1. Disconnect power, shut-off water and drain the unit by cracking eyewash valve open and allow to drain through bottom drain port.
2. Disconnect thermostat wires as follows (*refer to schematic attached to junction box or Section VII, Figures 8A-8C*) from terminal strip.

120VAC or 240VAC No Extra Heat Trace Cable – **2TB1** and **2TB3**

120VAC or 240VAC w/ Extra Heat Trace Cable – **2TB1** and **Contact 2 on 2CR**

3. Remove conduit from junction box by disconnecting union at junction box and disconnecting union from thermostat coupling.
4. Remove conduit on units with thermometer. Remove thermometer prior to removing cover.
5. Remove cover as described in this section (A. 4 - 6)
6. Remove thermostat to test in water bath. Test for contact closure by immersing in water 49°F (9°C), and contact opening by immersing in 60 to 70°F (15.5 - 21°C) water. If contact fails to open or close, replace with part number **01110479**.
7. Replacement is the reverse of disassembly.

V. TROUBLE SHOOTING

The Therma-Flow[®] shower and eyewash stations has a multitude of options, as such; a general description (page 1) of the station precedes the Troubleshooting segment of this manual. A station is depicted showing all options in drawing Section VII of this manual.

<u>PROBLEM</u>	<u>SOLUTION</u>
1. Water leaking from unit at:	Determine area of leak.
A. Freeze Protection Valve	A. The freeze proof valve opens when internal temperatures drop below 40°F (4°C). Activate eyewash and collect water in container. Insert thermometer and compare reading against specification, if water is above 45°F (7°C) valve should be closed. <i>See details in Section IV, E.</i>
B. Scald Protection Valve	B. The scald proof valve begins to open at 95°F (35°C). Perform Step above and compare if water temperature is below 92°F (33°C). <i>See details in Section IV, E.</i>
C. Unit piping	C. Equipment piping leaks are typically a result of mechanical damage or freezing. <i>See 2. Item C of this section.</i>
2. Unit freezing at:	
A. Eyewash only	A. Eyewash freezing is typically a result of trapped water in the eyewash due to: <ol style="list-style-type: none">1. 3-Way self-draining valve plugged, repair per <i>Section IV</i> of this manual.2. Eyewash covers replaced too quickly not allowing water to drain back to atmosphere, (30 to 90 seconds).3. Interrupted power supply; check continuous power supply to unit and thermostat. (Each unit requires 4 amps maximum.)
B. Shower head only	B. Slight freezing of water droplets is to be expected in extremely cold environments. This condition does not affect the operation of the equipment, as ice crystals will be removed upon equipment activation.
C. Complete unit	C. Unit freezing is a result of: electrical power failure, electric tracing failure, thermostat incorrectly wired, thermostat failure or insulation being saturated water.

DE-ENERGIZE PRIOR TO TESTING

1. Check power supply for proper voltage and circuit breaker for proper sizing. (Each unit requires 4 amps maximum).
2. With continuity tester, check to see that bus wires are intact and that there are no grounds between metal sheath and bus wires. Consult factory for further test procedures.

3. Circuit Breaker Trip

**CHECK GROUND
FAULT
INTERRUPTER
PRIOR TO
PROCEEDING**

3. Thermostat failure; thermostat can be tested while installed. Disconnect power and test for continuity, thermostat should close at 50°F (10°C) or below, and open at 65°F (18°C) or above. If warm water source is not available, remove thermostat. See Section IV, F for instructions.

- A. Circuit breaker trip is typically a result of a ground fault or short circuit. With power disconnected, a continuity test (power to ground) should be performed. Areas of potential failure include junction box connections, cable termination seal, or splice where heat shrink insulators are located or have become damaged. Repair as required.
- B. Circuit breaker trip can also be attributed to overloading circuit breakers, i.e., too many devices powered from a single power feed. Each unit will draw a maximum of 4 amps at cold start up. Cold start up conditions cause a higher current draw than normal (in-rush current). Electrical tracing circuit breakers must be sized with in-rush current as criteria.

4. Water Temperature Too Hot

High water temperature in shower and eyewash equipment can generally be attributed to supply water temperature, radiant heat input from ambient conditions, or heat transfer from adjacent piping systems. Insulate or Isolate as required. If radiant heat is a continual problem, a scald proof valve should be retrofitted to the equipment for personnel protection reasons. Assure that thermostat is wired correctly. (Thermostat opens on rise in temperature and closes on fall.)

5. Alarms

Activation of alarms is by flow switch or MAP[®] switch

A. Will not shut-off switch

A. A flow switch may become stuck open (energized) by metal shavings or pipe scale. Disconnect power, remove bonnet, clean shuttle as required. (See Section VII, Figure 6A and 6B)

B. Will not Shut-Off MAP[®] Switch

B. MAP[®] switches may require repositioning after a period of time due to usage. Readjust as required or 10° angle for MAP[®] Switch. (No greater than 1" [25 mm] of clearance between contacts).

C. Will not Energize Light

C. Check bulb in alarm light.

D. Will not Energize; and Light Bulb is OK

D. Check continuity of alarm circuit per wiring diagram, Section VII. (See Figure 8A-8C).

E. Will not Energize Bell/Horn

E. Check for debris in switch per A and B above. Shavings, rocks, and objects can prevent switches from closing, the alarm will not energize. If energized (alarm) local and remote will be constant.

F. Will not Energize Remote Alarm

F. See A, B, and D above and check relay, located in junction box, for proper wiring. Relay is rated at 3 amps or 10 amps/120 or 240 volt.

VI. RECOMMENDED SPARE PARTS - THERMA-FLOW®

NOTE: RECOMMENDED ON HAND SPARE PARTS ARE HIGHLIGHTED
CF = CONSULT FACTORY

NOMENCLATURE	PART NO.
SHOWER PARTS	
ACTUATOR ARM WITH WELD BLOCK	01110152
BALL VALVE, 1¼" (SHOWER)	00011022
BALL VALVE EXTENSION KIT (INCLUDES GROMMET, EXTENSION, SCREW, ACTUATOR ARM W/ WELD BLOCK)	01052532
BALL VALVE EXTENSION KIT SST (SHOWER)	01052545
BALL VALVE REPAIR KIT, 1¼" (SHOWER) (INCLUDES O-RINGS AND BALL VALVE SEATS)	00011053
BALL VALVE EXTENSION (SHOWER)	01110147
GROMMET COVER (SHOWER HEAD)	00014554
GROMMET 1¼" I.D. FOR BALL VALVE EXTENSION (SHOWER)	00013644
NUT FOR SHOWER ACTUATOR ARM	00011201
PULL ROD ASSEMBLY (SHOWER) (INCLUDES PULL ROD AND ACTUATOR ARM)	35052460M
PULL ROD ONLY (SHOWER)	01052003
PULL ROD WITH DECAL & FASTENER	01052001
SCREW, SELF-LOCKING FOR BALL VALVE EXTENSION (SHOWER)	00012614
SHOWER HEAD, 20 GPM (4.5 m³/hr) (REGULATOR INCLUDED)	01054005
SHOWER HEAD, 30 GPM (6.8 m³/hr) (REGULATOR INCLUDED)	01054003
WASHER FOR BALL VALVE EXTENSION (SHOWER)	00011101

EYEWASH PARTS

BALL VALVE, ½" SELF-DRAINING (EYEWASH)	00011059
BALL VALVE EXTENSION (EYEWASH)	01110142
BALL VALVE EXTENSION KIT (INCLUDES GROMMET, EXTENSION, SCREW, PUSH PLATE)	01052515
BALL VALVE EXTENSION KIT SST (EYEWASH)	01052544
BALL VALVE REPAIR KIT, ½" (EYEWASH) (INCLUDES O-RINGS AND BALL VALVE SEATS)	00011052
CAP COVER	01110500
DRAIN TUBE (EYEWASH)	00008500
EYEWASH ASSEMBLY WITH POP-OFF COVERS	01052123
GROMMET FOR DRAIN TUBE (EYEWASH)	00013676
GROMMET (EYEWASH ASSEMBLY-TOP CENTER OUTLET LOCATION)	00013676
GROMMET (EYEWASH PUSH PLATE)	00013676
NIP PLASTIC ½" x 2½" (EYEWASH)	00008504
NUT FOR EYEWASH BALL VALVE EXTENSION	00011206
PIPE (PVC) ½"	01360024
PUSH PLATE SST WITH WELD BLOCK	01052016
SCREW, SELF-LOCKING FOR PUSH PLATE	00012852

VI. RECOMMENDED SPARE PARTS - THERMA-FLOW®

NOTE: RECOMMENDED ON HAND SPARE PARTS ARE HIGHLIGHTED
CF = CONSULT FACTORY

NOMENCLATURE **PART NO.**

ALARM PARTS

ALARM BELL 120 VOLT	00013389
ALARM BELL 240 VOLT	00013387
ALARM BOX (BELL)	00013388
ALARM FLASHER 120 VOLT	00013575
ALARM FLASHER 240 VOLT	00013662
ALARM HORN 120 VOLT	00014460
ALARM HORN 240 VOLT	00014462
FLOW SWITCH, 2GPM, 1", 120V	00014685
FLOW SWITCH BONNET, 1"	00014685
FLOW SWITCH SHUTTLE	00014683
GROMMET (ALARM)	00014518
GROMMET (FLOW SWITCH BONNET)	00014517
GROMMET (FLOW SWITCH INLET)	00014554
MAGNET CAP FOR MAP® PROXIMITY SWITCH	00013007
MAGNET ONLY FOR MAP® PROXIMITY SWITCH	00013324
MAGNET & SWITCH FOR MAP® PROXIMITY SWITCH	00013319
MAP® PROXIMITY SWITCH REPAIR KIT SHOWER/DRENCH HOSE (INCLUDES SWITCH, CAP, MAGNET, & TILT BRACKET)	01052326
MAP® PROXIMITY SWITCH REPAIR KIT EYEWASH (INCLUDES SWITCH, CAP, MAGNET, & TILT BRACKET)	01052325
O-RING FOR FLOW SWITCH BONNET	00014677
PULSE TONE AUDIO 120 VOLT (2 EACH)	00014482
PULSE TONE AUDIO 240 VOLT (2 EACH)	00014486
RELAY SOCKET FOR FLOW SWITCH OR MAP® SWITCH 120 VOLT	00014638
RELAY SOCKET FOR FLOW SWITCH OR MAP® SWITCH 240 VOLT	00014619
RELAY FOR ALARM 120 VOLT, 3 AMP	00013393
RELAY FOR ALARM 120 VOLT, 10 AMP	00014620
RELAY FOR ALARM 240 VOLT, 3 AMP	00013252
RELAY FOR ALARM 240 VOLT, 10 AMP	00014703
RESET BUTTON (PULSE TONE 120/240 VOLT)	00014628
SWITCH ONLY FOR MAP® PROXIMITY SWITCH	00013325
TILT BRACKET (SHOWER MAP® PROXIMITY SWITCH)	00014708
TILT BRACKET (EYEWASH MAP® PROXIMITY SWITCH)	00014709
TILT BRACKET (DRENCH HOSE MAP® PROXIMITY SWITCH)	00014708
UNILET GASKET (MAP® PROXIMITY SWITCH)	00013470
UNILET COVER (MAP® PROXIMITY SWITCH)	00013447

VI. RECOMMENDED SPARE PARTS - THERMA-FLOW®

NOTE: RECOMMENDED ON HAND SPARE PARTS ARE HIGHLIGHTED
CF = CONSULT FACTORY

NOMENCLATURE

PART NO.

COVER ASSEMBLIES

(Consult factory for other colors).

YELLOW

24" (609.6 mm) OVERHEAD LEFT SIDE (JUNCTION BOX)	01110652
24" (609.6 mm) OVERHEAD RIGHT SIDE	01110650
24" (609.6 mm) OVERHEAD RIGHT SIDE (ALARM)	01110651
24" (609.6 mm) OVERHEAD LEFT SIDE (JUNCTION BOX & ALARM LIGHT)	01110653
32" (813.8 mm) OVERHEAD LEFT SIDE (JUNCTION BOX & ALARM LIGHT)	01110657
32" (813.8 mm) OVERHEAD LEFT SIDE (JUNCTION BOX)	01110656
32" (813.8 mm) OVERHEAD RIGHT SIDE (DRENCH HOSE)	01110654
32" (813.8 mm) OVERHEAD RIGHT SIDE (DRENCH HOSE & ALARM)	01110655
EYEWASH LEFT SIDE (TOP CENTER OUTLET)	01110677
EYEWASH RIGHT SIDE (TOP CENTER OUTLET)	01110680
LOWER VERTICAL LEFT SIDE	01110666
LOWER VERTICAL RIGHT SIDE	01110665
UPPER VERTICAL LEFT SIDE (THERMOSTAT)	01110659
UPPER VERTICAL LEFT SIDE (THERMOSTAT & THERMOMETER)	01110660
UPPER VERTICAL RIGHT SIDE	01110658

GREEN

24" (609.6 mm) OVERHEAD LEFT SIDE (JUNCTION BOX)	01110652G
24" (609.6 mm) OVERHEAD RIGHT SIDE	01110650G
24" (609.6 mm) OVERHEAD RIGHT SIDE (ALARM)	01110651G
24" (609.6 mm) OVERHEAD LEFT SIDE (JUNCTION BOX & ALARM LIGHT)	01110653G
32" (813.8 mm) OVERHEAD LEFT SIDE (JUNCTION BOX & ALARM LIGHT)	01110657G
32" (813.8 mm) OVERHEAD LEFT SIDE (JUNCTION BOX)	01110656G
32" (813.8 mm) OVERHEAD RIGHT SIDE (DRENCH HOSE)	01110654G
32" (813.8 mm) OVERHEAD RIGHT SIDE (DRENCH HOSE & ALARM)	01110655G
EYEWASH LEFT SIDE (TOP CENTER OUTLET)	01110677G
EYEWASH RIGHT SIDE (TOP CENTER OUTLET)	01110680G
LOWER VERTICAL LEFT SIDE	01110666G
LOWER VERTICAL RIGHT SIDE	01110665G
UPPER VERTICAL LEFT SIDE (THERMOSTAT)	01110659G
UPPER VERTICAL LEFT SIDE (THERMOSTAT & THERMOMETER)	01110660G
UPPER VERTICAL RIGHT SIDE	01110658G

VI. RECOMMENDED SPARE PARTS - THERMA-FLOW®

NOTE: RECOMMENDED ON HAND SPARE PARTS ARE HIGHLIGHTED

CF = CONSULT FACTORY

NOMENCLATURE **PART NO.**

ACCESSORY PARTS

BALL VALVE, ¾" (19.05 mm) (DRENCH HOSE)	00011044
BALL VALVE, 3-WAY 1¼" (31.75mm) (UNDERGROUND EXTENSION SHUTOFF)	00011097
BALL VALVE EXTENSION (DRENCH HOSE)	01110153
BALL VALVE EXTENSION KIT (DRENCH HOSE) (INCLUDES EXTENSION, VALVE STOP)	01052528
BALL VALVE EXTENSION KIT SST (DRENCH HOSE)	01052546
BALL VALVE REPAIR KIT ¾" (19.05 mm) (DRENCH HOSE) (INCLUDES O-RINGS AND BALL VALVE SEATS)	CF
BULB 120 VOLT (HEAT TRACE INDICATOR)	00014538
BULB 240 VOLT (HEAT TRACE INDICATOR)	00013543
BULB, BASE SOCKET	00014500
DRAIN TUBE (FREEZE / SCALD PROTECTION VALVES)	00008500
DRENCH HOSE ASSEMBLY	01050149
GLOBE, BLUE (AREA LIGHT)	00013582
GLOBE, CLEAR (AREA LIGHT)	00013460
GLOBE, GREEN (AREA LIGHT)	00013571
GLOBE, RED (ALARM LIGHT)	00014606
GROMMET FOR BALL VALVE EXTENSION (DRENCH HOSE) AND THERMOMETER	00014518
GROMMET (AREA LIGHT)	00014551
GROMMET (DRENCH HOSE)	00013643
GROMMET (FLOOR FLANGE AND WATER INLET)	00014555
GROMMET (FREEZE / SCALD PROTECTION VALVES AND HEAT TRACE ALARM LIGHT)	00014517
GROMMET (JUNCTION BOX AND THERMOSTAT)	00014519
GROMMET (STRAINER CAP)	00013603
GROMMET SOLID (WATER INLET AND SHOWER)	00014525
INSULATION, 2" (50.8 mm) IPS x ½" (12.7 mm) THK #620 ARMAFLEX	00013545
INSULATION, 1" (25.4 mm) ID x ¾" (19.05 mm) THK	00014504
INSULATION, 1½" (38.1 mm) IPS x ½" (12.7 mm) THK	01360177
LENS, AMBER (HEAT TRACE INDICATOR)	00014532
LENS, RED (HEAT TRACE INDICATOR)	00014531
LIGHT GUARD (CSA FIXTURE)	00013612
PULL ROD ASSEMBLY (DRENCH HOSE)	35052461
PULL ROD ONLY (DRENCH HOSE)	01110008
REGULATOR, 3 GPM (0.68 m ³ /hr) (DRENCH HOSE)	00011901
SIGN, AWARENESS 360°™ (See Figure 10 for reference)	35001810
SNAP-LET OUTLET 1¼" x ½"	00002232
TAPE FOAM 1/8 x 1/2 x 75'	00013727
TAPE ARMAFLEX INSULATION 2" (50.8 mm) x 30' (9.14 m) (FULL ROLLS ONLY)	01360174
THERMOMETER	00013303
THERMOSTAT	01110479
THERMOWELL	00013308
TRIM STRIP	00013454
VALVE, FREEZE PROTECTION	00011020
VALVE, SCALD PROTECTION	00011021

VII. DRAWINGS AND DIAGRAMS

Therma-Flow®

FIGURE 1A	EMERGENCY SHOWER DIMENSIONAL
FIGURE 1B	OVERHEAD SECTION & UPPER VERTICAL DIMENSIONAL
FIGURE 1C	OVERHEAD SECTION & UPPER VERTICAL ASSEMBLY
FIGURE 1D	LOWER VERTICAL & FOUNTAIN ASSEMBLY
FIGURE 1E	THERMOSTAT ASSEMBLY
FIGURE 2	DRENCH HOSE W/ STRAINER ASSEMBLY
FIGURE 3A	EYEWASH ASSEMBLY
FIGURE 3B	EYEWASH COVER OVERLAP ASSEMBLY
FIGURE 3C	EYEWASH BALL VALVE ASSEMBLY
FIGURE 4	FREEZE & SCALD PROTECTION VALVES
FIGURE 5	UNDERGROUND EXTENSION WITH AND WITHOUT FLOW SWITCH
FIGURE 6A	FLOW SWITCH AND SCHEMATIC
FIGURE 6B	FLOW SWITCH MECHANICAL ASSEMBLY
FIGURE 7A	MAP® SWITCH ASSEMBLY
FIGURE 7B	MAP® SWITCH SCHEMATIC
FIGURE 8A	WIRING DIAGRAM – 120 VOLT
FIGURE 8B	WIRING DIAGRAM – 120 VOLT w/ EXTRA HEAT TRACE CABLE
FIGURE 8C	WIRING DIAGRAM – 240 VOLT
FIGURE 8D	WIRING DIAGRAM – 240 VOLT w/ EXTRA HEAT TRACE CABLE
FIGURE 8E	WIRING DIAGRAM – PULSE TONE AUDIBLE ALARM
FIGURE 9	COVER ASSEMBLY
FIGURE 10	AWARENESS 360°™ SIGN
FIGURE 11	EYEWASH BALL VALVE EXTENSION RETROFIT KIT
FIGURE 12	MAP® SWITCH REPAIR PARTS KIT
FIGURE 13	INSPECTION REPORT

Drawings and diagrams included are for reference. They contain general information and may not be “as-built” to your specific model.

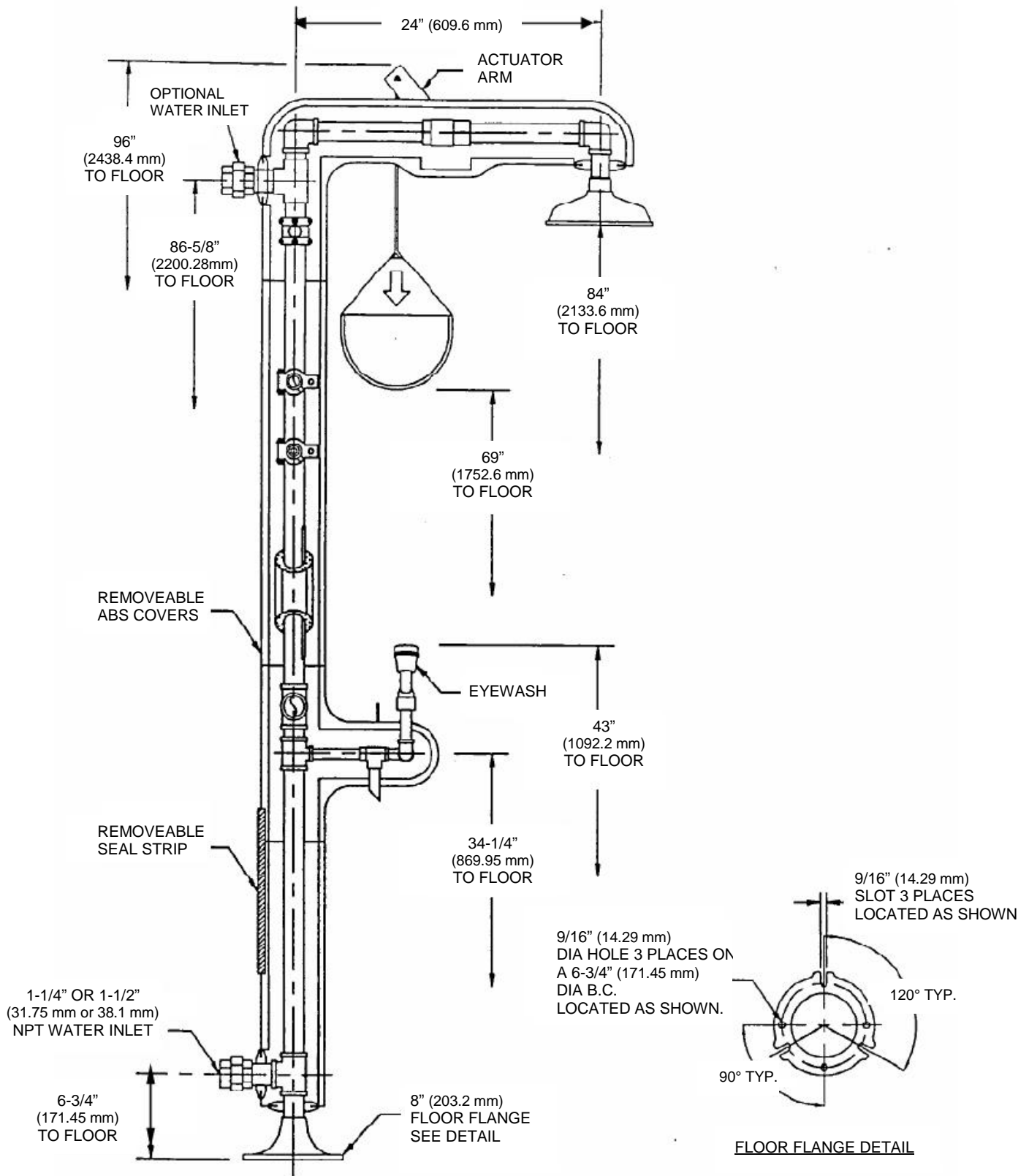
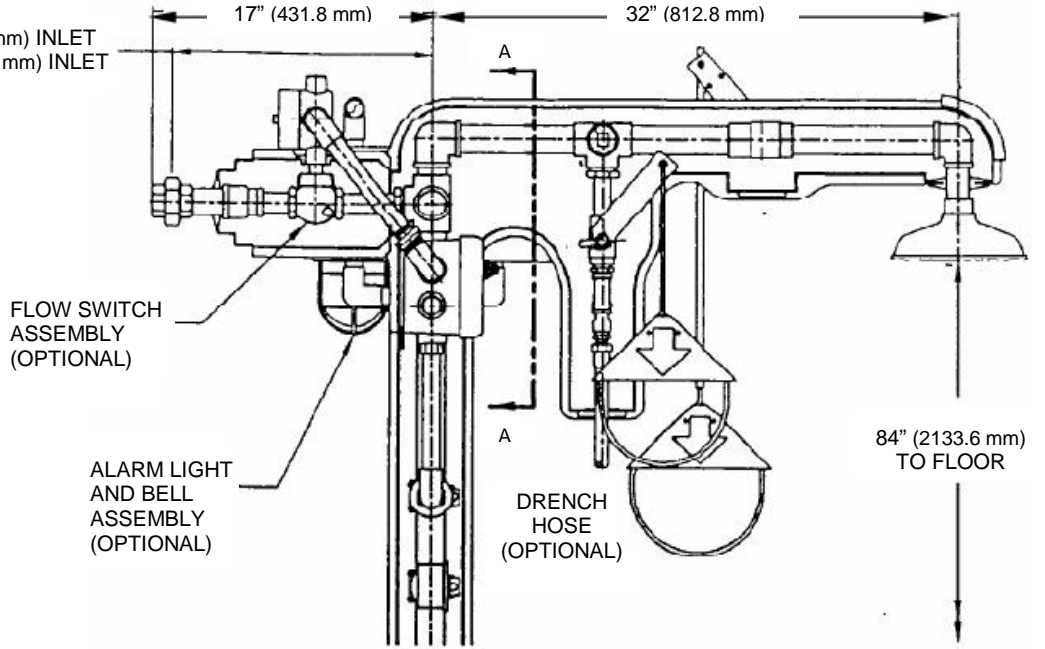
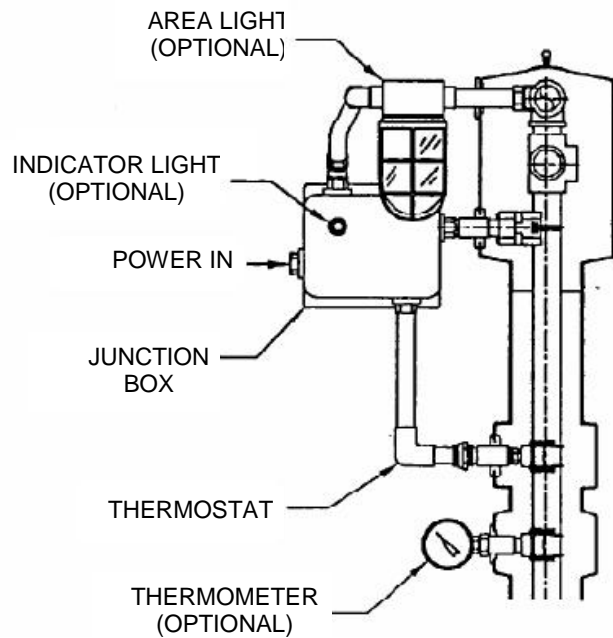

Figure 1A. EMERGENCY SHOWER DIMENSIONAL

15-3/4" (400.05 mm) for 1-1/4" (31.75 mm) INLET
 15-11/16" (398.46 mm) for 1-1/2" (38.1 mm) INLET



LEFT-SIDE VIEW



SECTION "A-A"

Figure 1B. OVERHEAD SECTION & UPPER VERTICAL

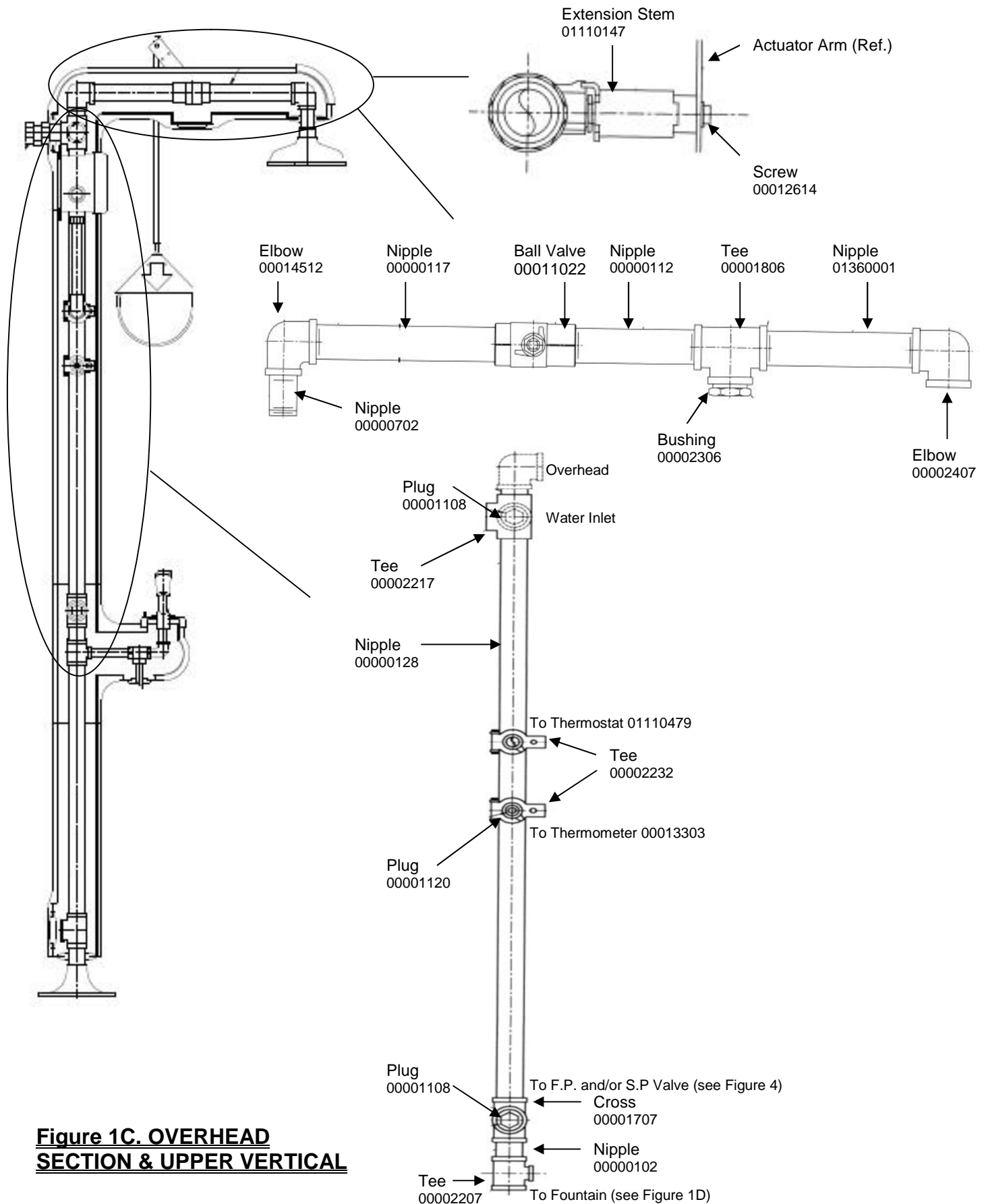

Figure 1C. OVERHEAD SECTION & UPPER VERTICAL

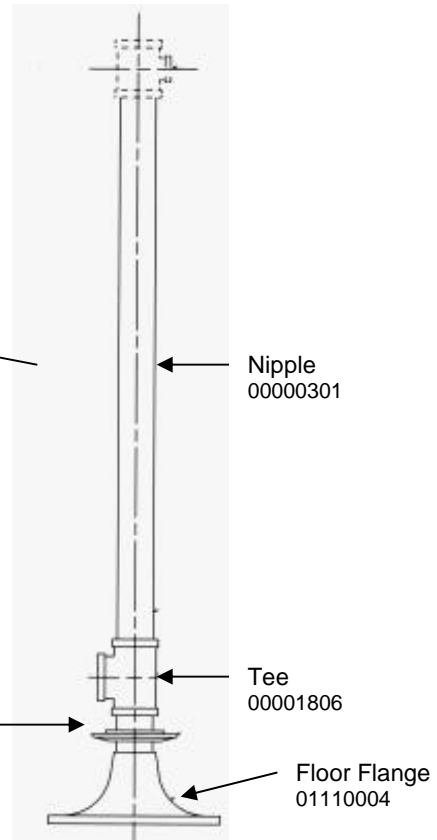
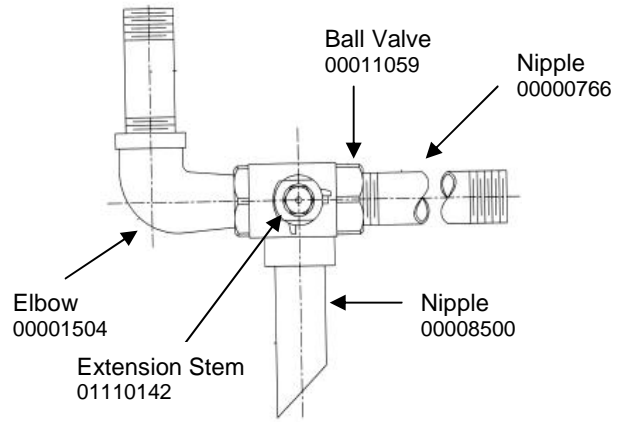
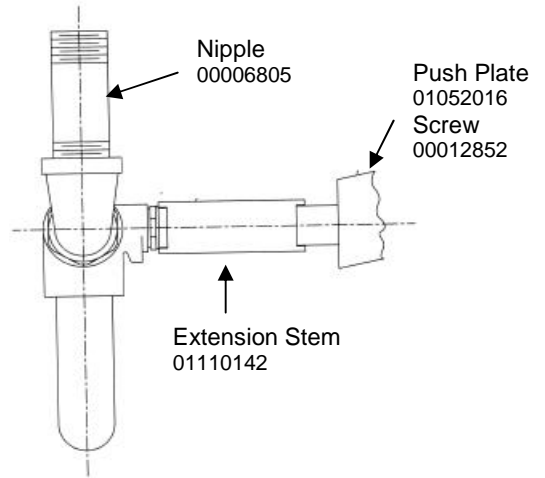
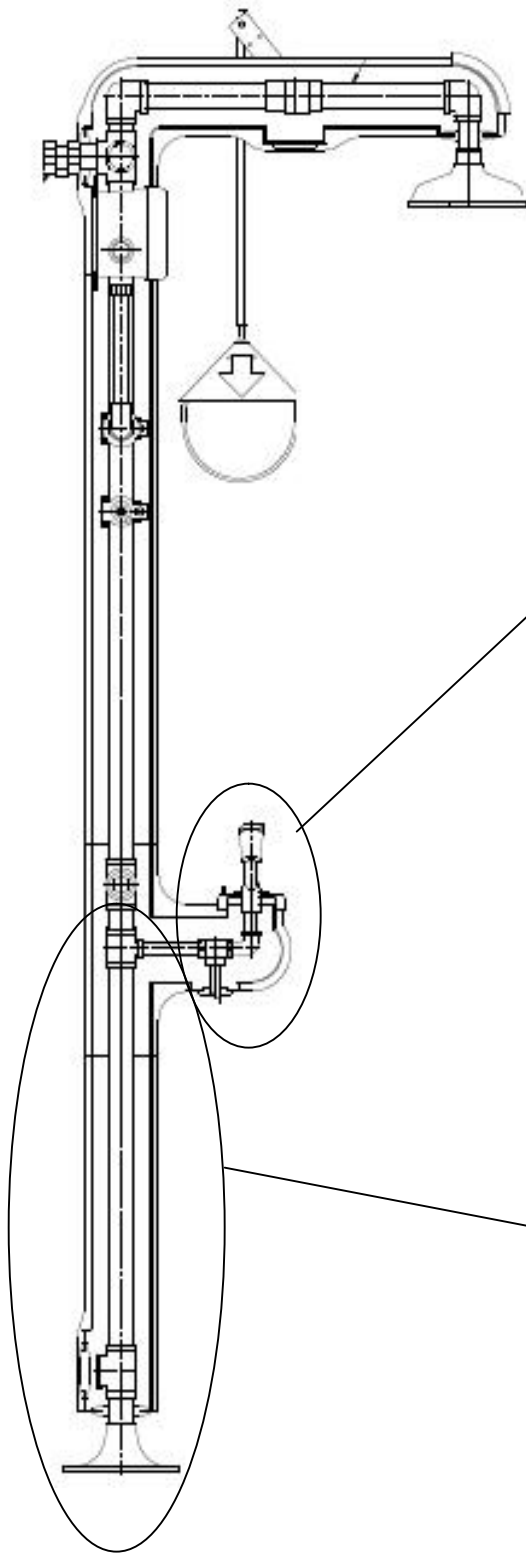

Figure 1D. LOWER VERTICAL & FOUNTAIN SUBASSEMBLY

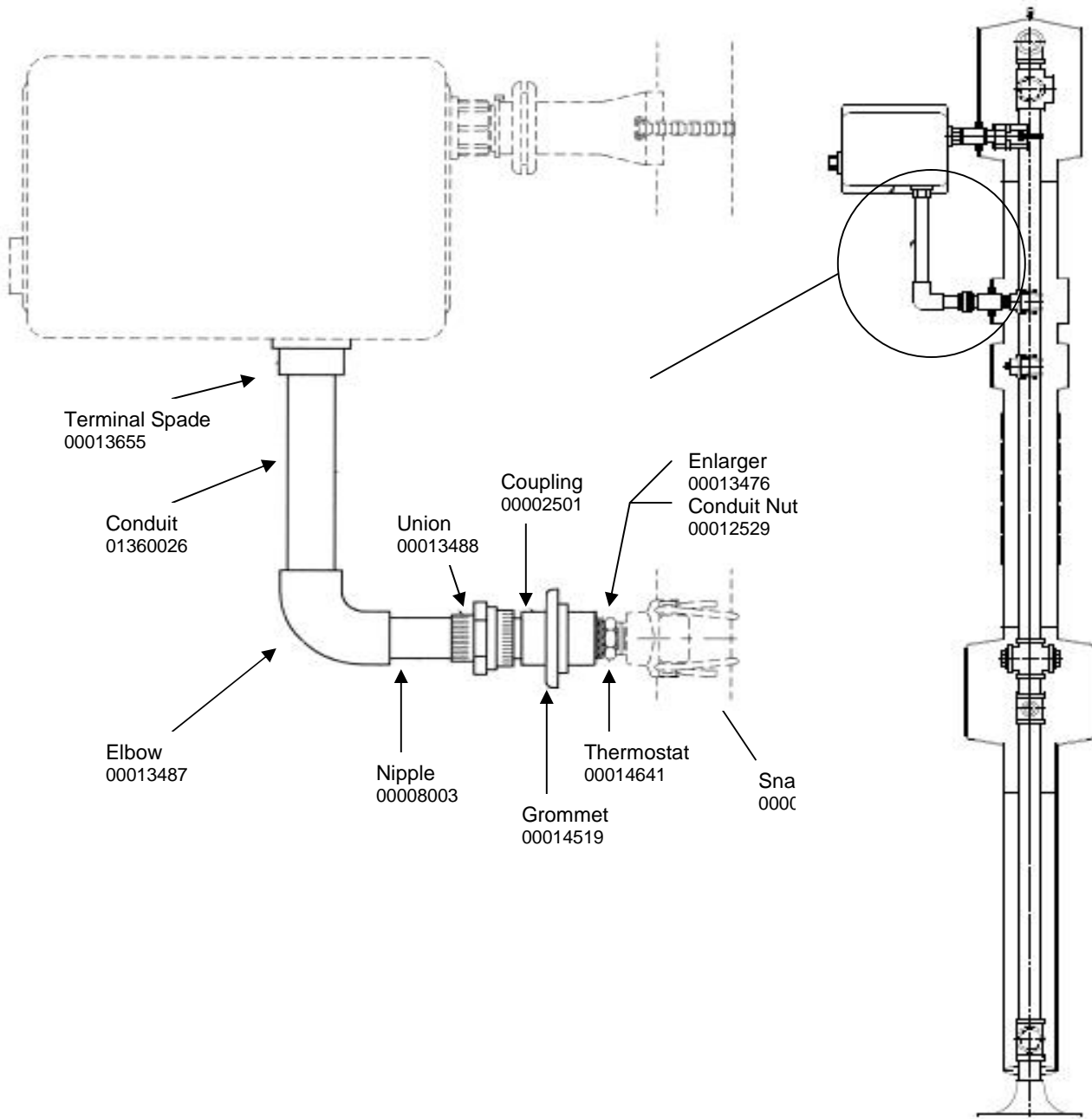

Figure 1E. THERMOSTAT ASSEMBLY

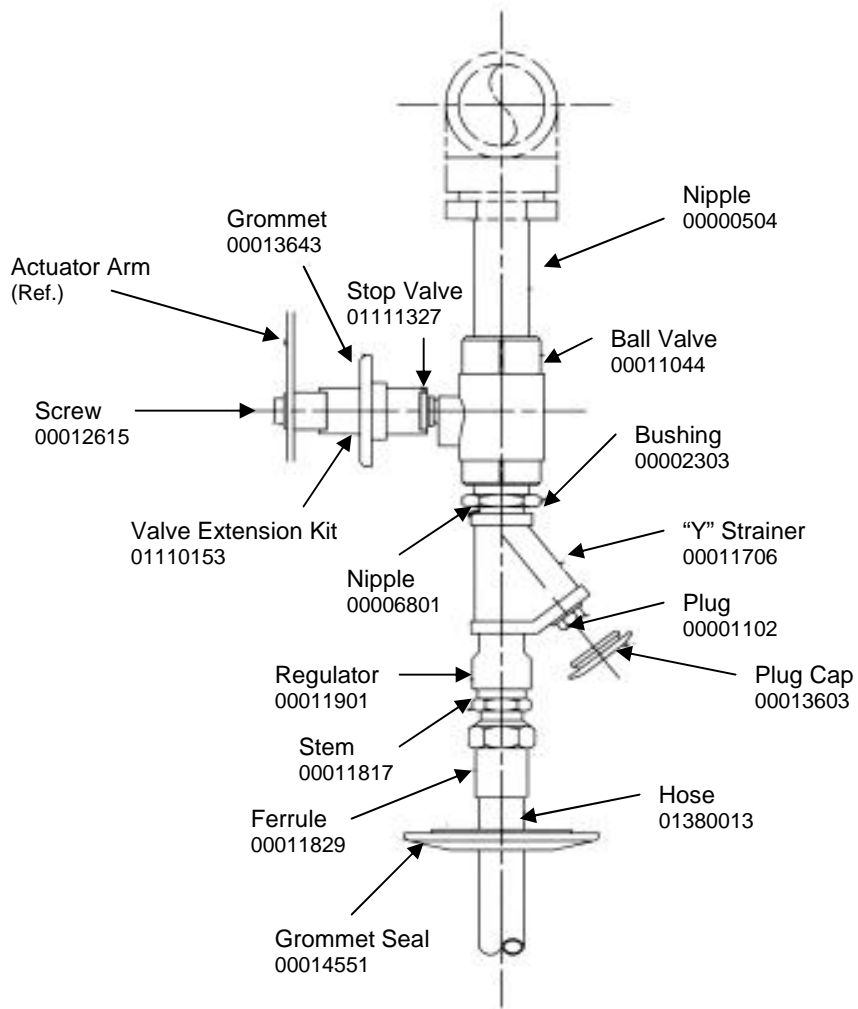

Figure 2. DRENCH HOSE W/ STRAINER ASSEMBLY

VALVE EXTENSION
TOP CENTER OUTLET EYEWASH HEAD

Eyewash Yoke w/ Pop-off Covers
01052123

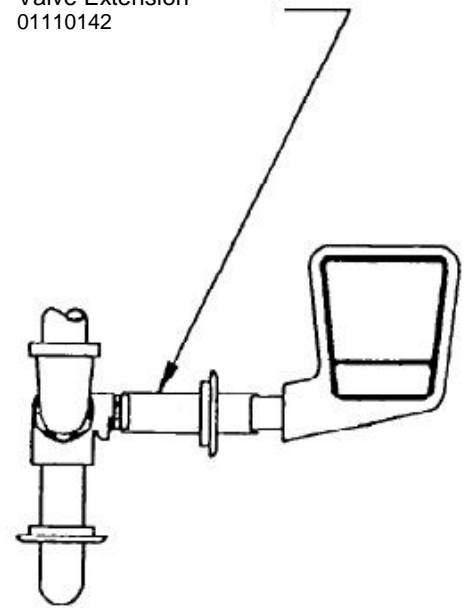
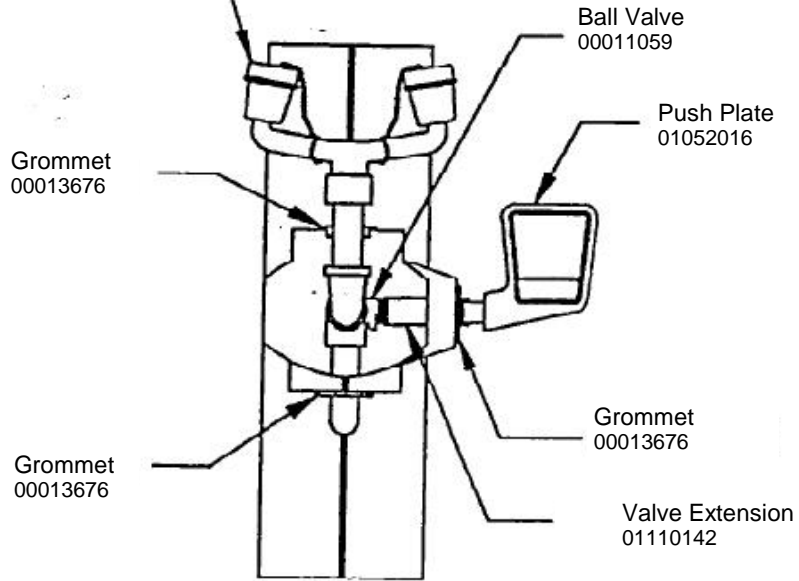
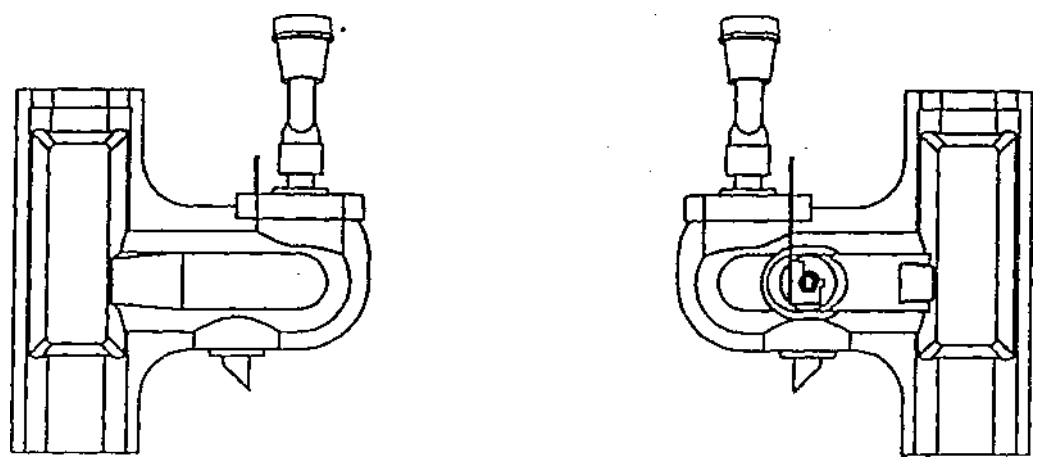
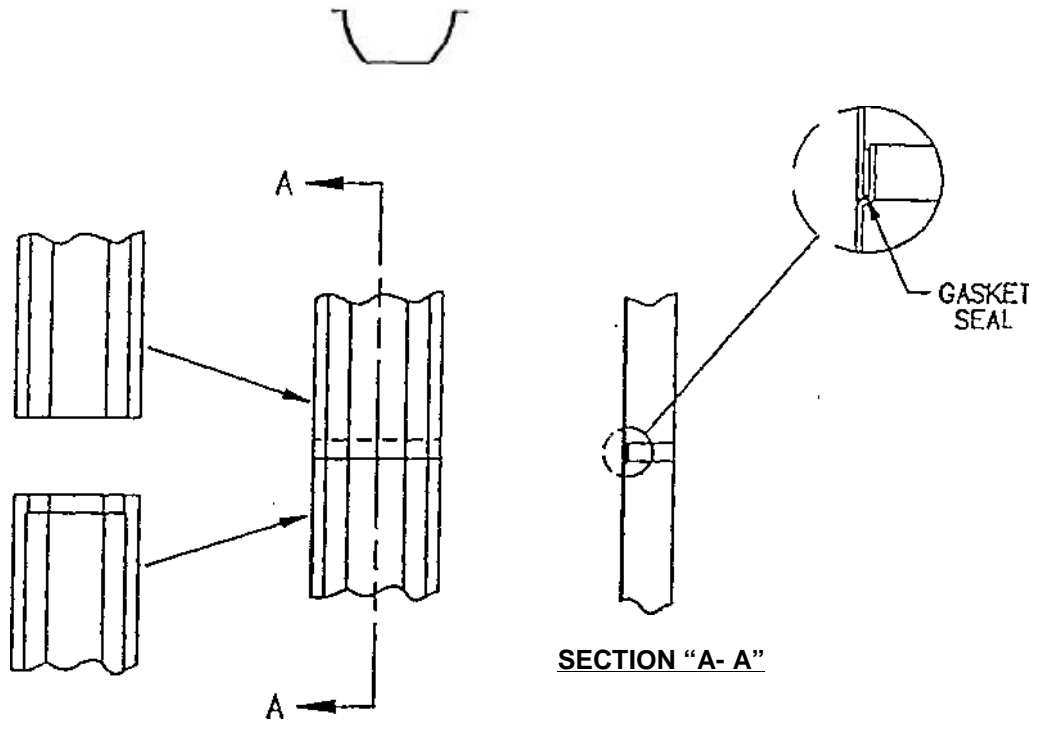

Figure 3A. EYEWASH ASSEMBLY
(VALVE EXTENSION)



LEFT-SIDE VIEW

RIGHT-SIDE VIEW

Figure 3B. EYEWASH COVER OVERLAP ASSEMBLY

2 Way Valve Assembly



STEM GLAND NUT



STEM PACKING



VALVE STEM



VALVE STEM THRUST WASHER

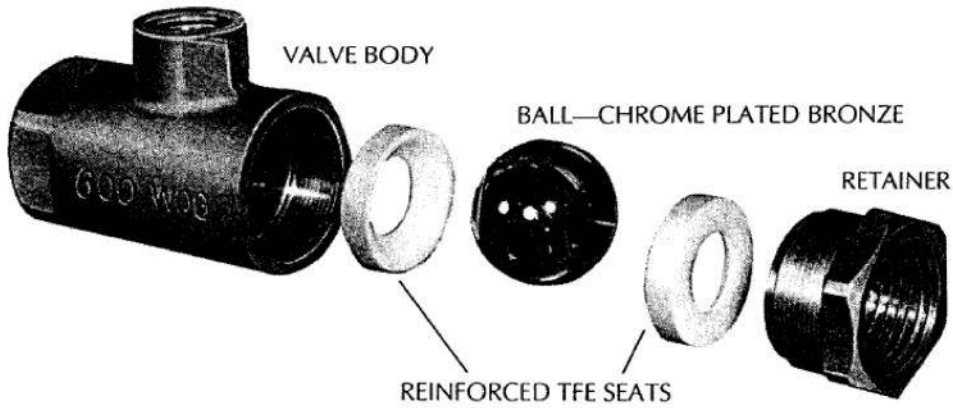

3 Way Valve Assembly

DURING VALVE REPAIR ASSURE WATER IS SHUT OFF AND DRAINED PRIOR TO PERFORMING REPAIR.

*SELF DRAINING 3-WAY VALVES HAVE A FLAT ON ONE SIDE OF THE VALVE, AFTER ASSEMBLY INSURE THAT THE FLAT IS VISIBLE FROM THE WATER FLOW PATH OUTLET WHEN VALVE IS IN THE OFF POSITION.

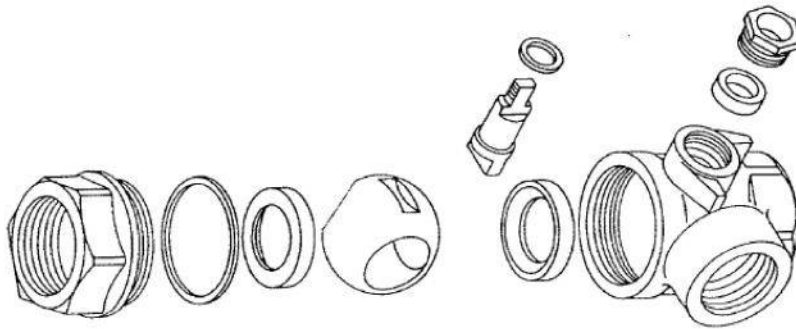

Figure 3C. EYEWASH BALL VALVE ASSEMBLY

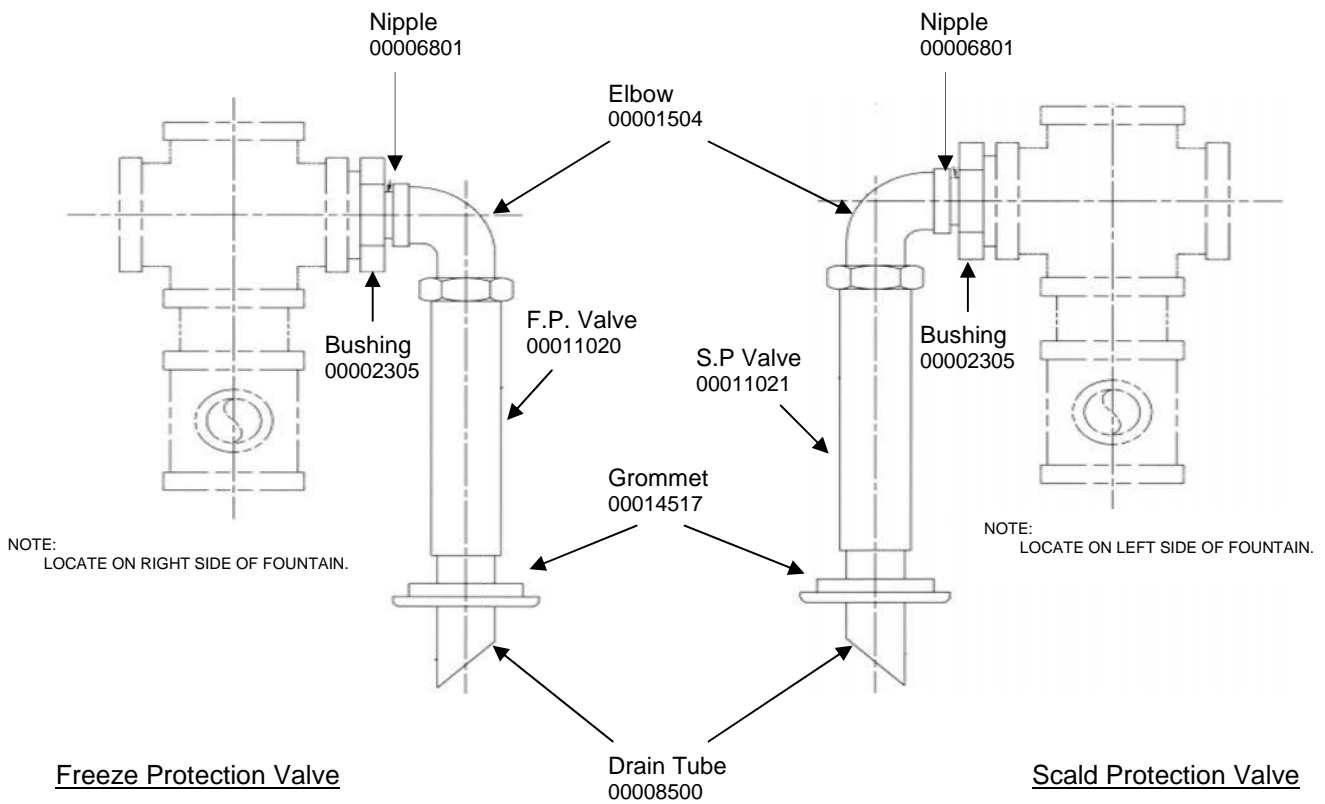
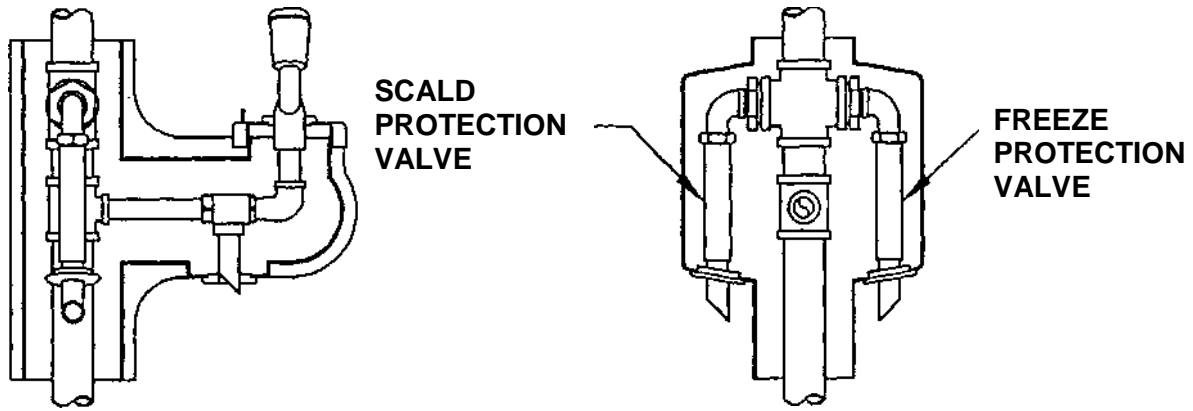
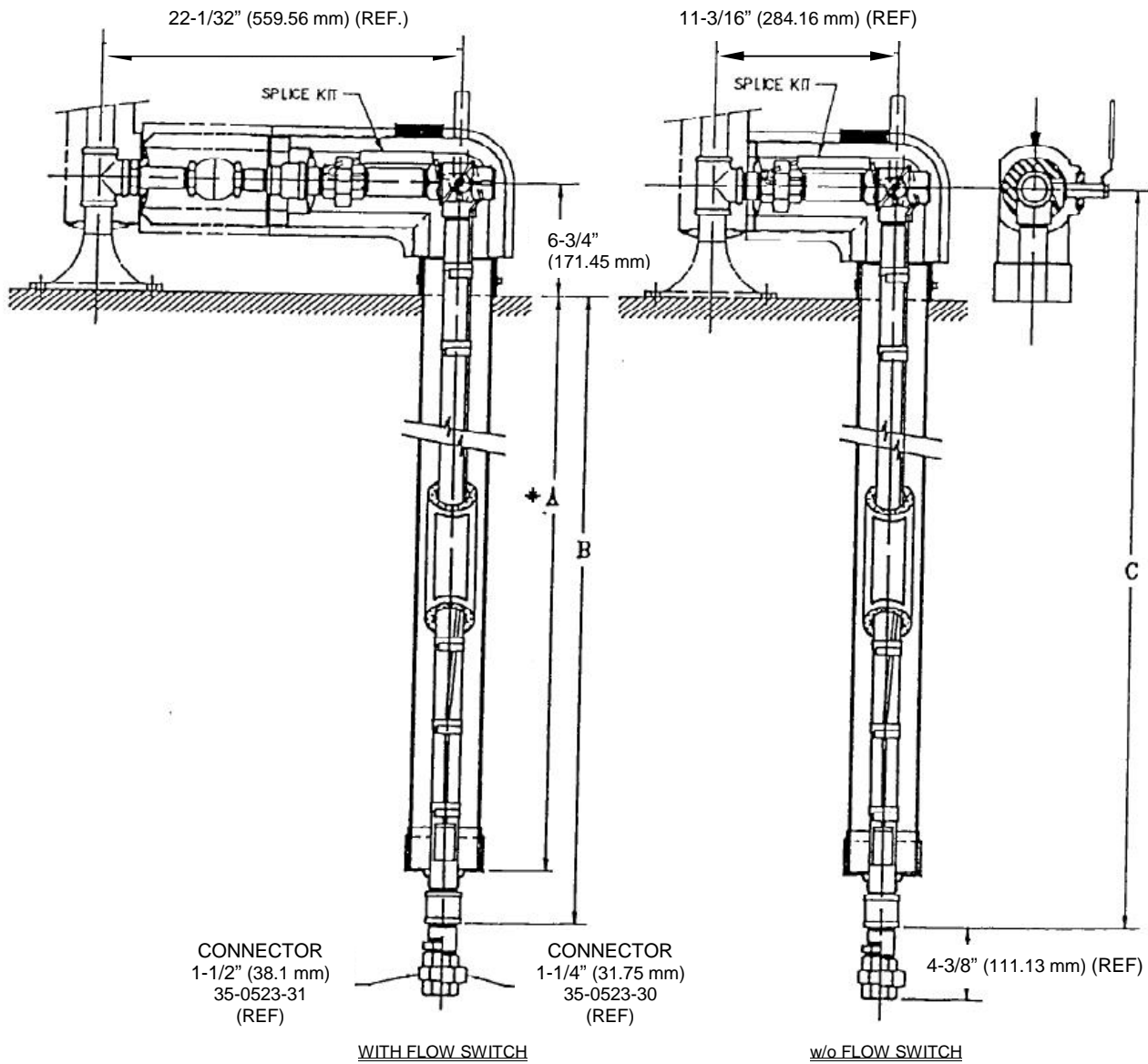

Figure 4. FREEZE (F.P.) & SCALD (S.P.) PROTECTION VALVES

SIZE	120V PART NO.	240V PART NO.	*A	B	C
2'-0" (0.61 m)	35-0523-80	35-0523-85	22" (558.8 mm)	25-15/16" (658.81 mm)	32-11/16" (830.26 mm)
2'-6" (0.61 m-152.4 mm)	35-0523-81	35-0523-86	28" (711.2 mm)	31-15/16" (811.21 mm)	38-11/16" (982.66 mm)
3'-0" (0.91 m)	35-0523-82	35-0523-87	34" (863.6 mm)	37-15/16" (963.61 mm)	44-11/16" (1135.06 mm)
3'-6" (0.91m-15.4 mm)	35-0523-83	35-0523-88	40" (1016 mm)	43-15/16" (1116.01 mm)	50-11/16" (1287.46 mm)
4'-0" (1.22 m)	35-0523-84	35-0523-89	46" (1168.4 mm)	49-15/16" (1268.41 mm)	56-11/16" (1439.86 mm)

NOTES:

- * 1. FREEZE PROTECTED DEPTH.
- 2. TO PREVENT ACCIDENTAL CLOSURE OF VALVE, OPERATOR MUST PLACE VALVE IN "OPEN" POSITION, THEN REMOVE HANDLE.



**Figure 5. UNDERGROUND EXTENSION
(WITH AND WITHOUT FLOW SWITCH)**

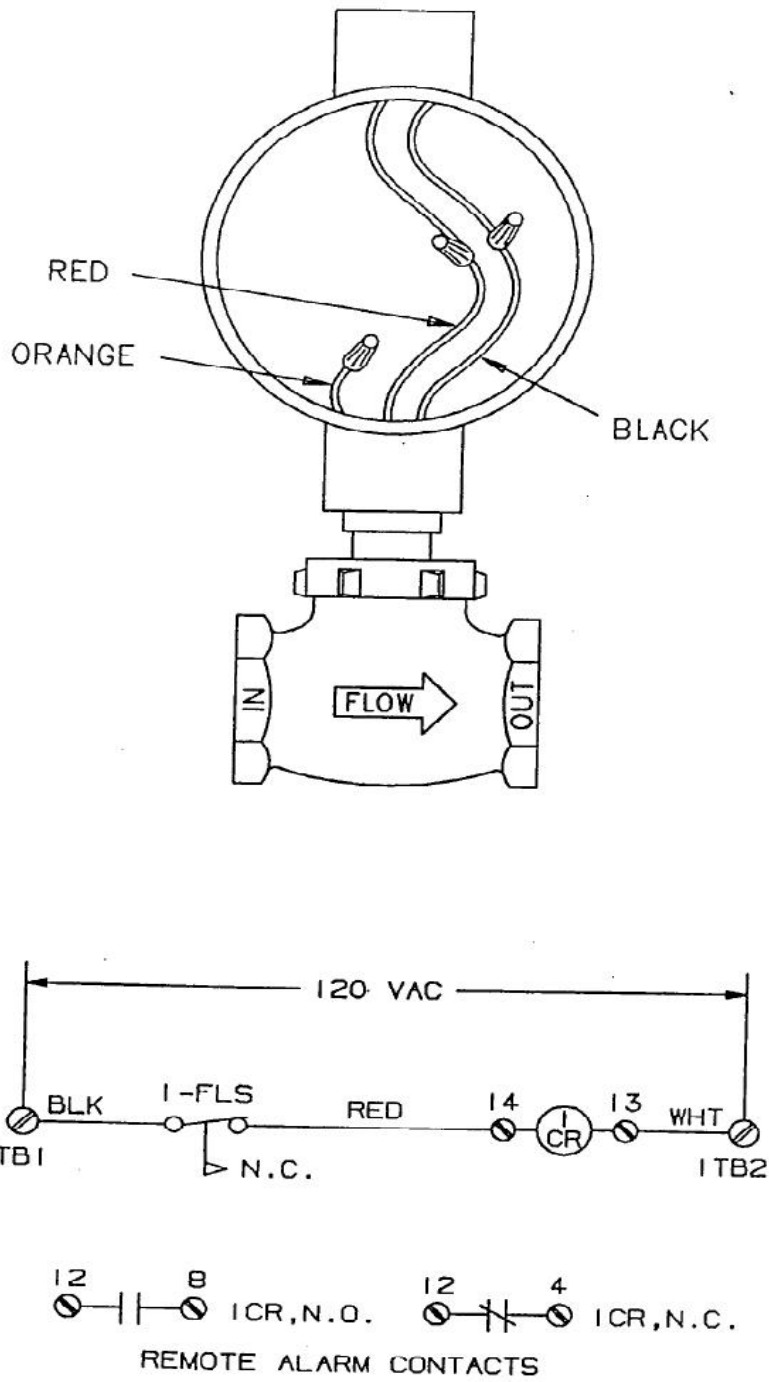

Figure 6A. FLOW SWITCH AND SCHEMATIC

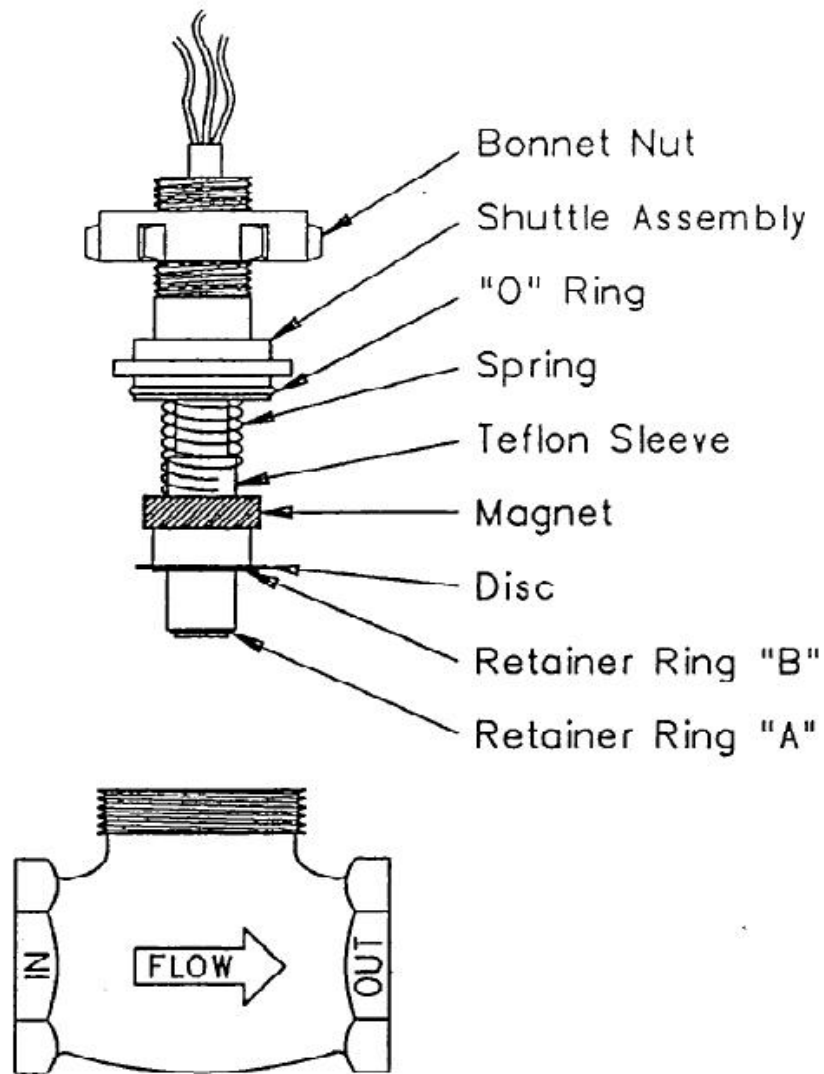
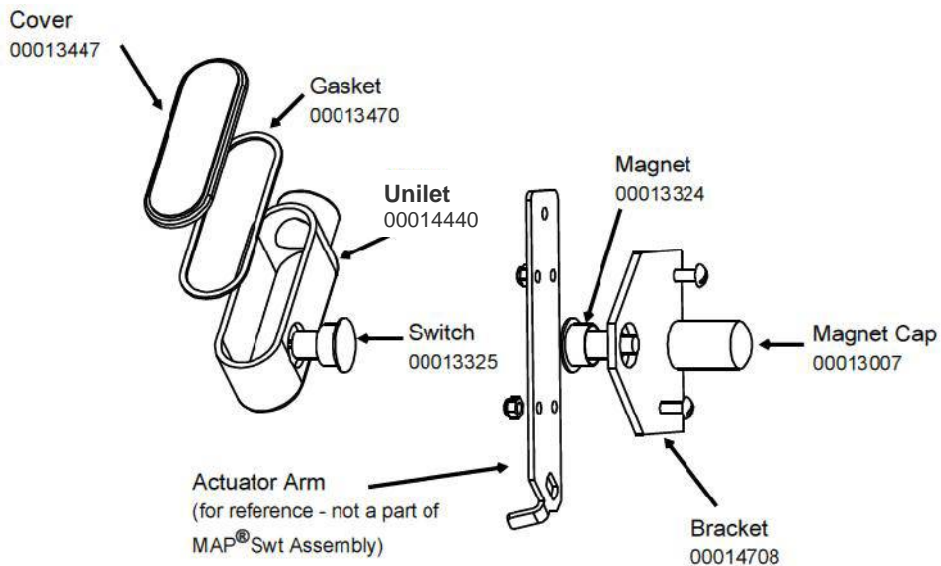
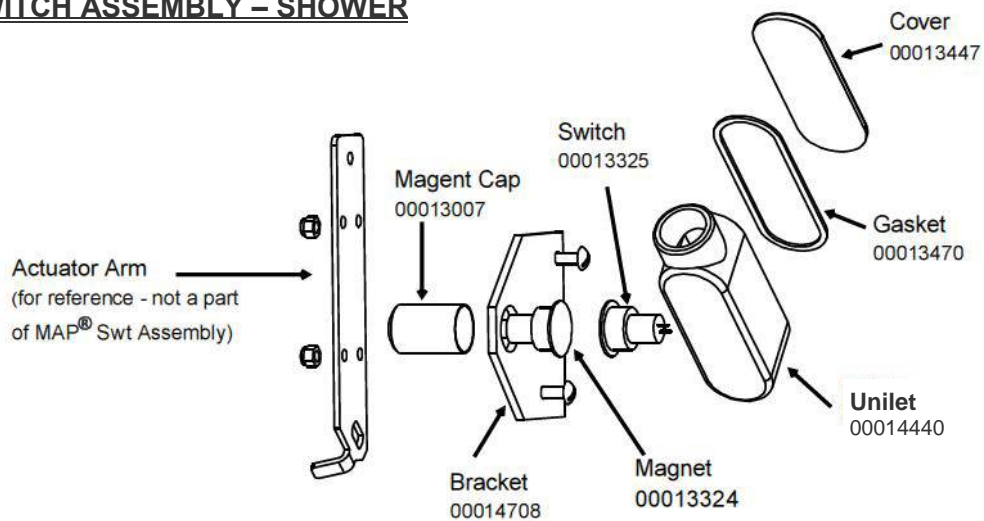

Figure 6B. FLOW SWITCH MECHANICAL ASSEMBLY



MAP® SWITCH ASSEMBLY – SHOWER



MAP® SWITCH ASSEMBLY – DRENCH HOSE

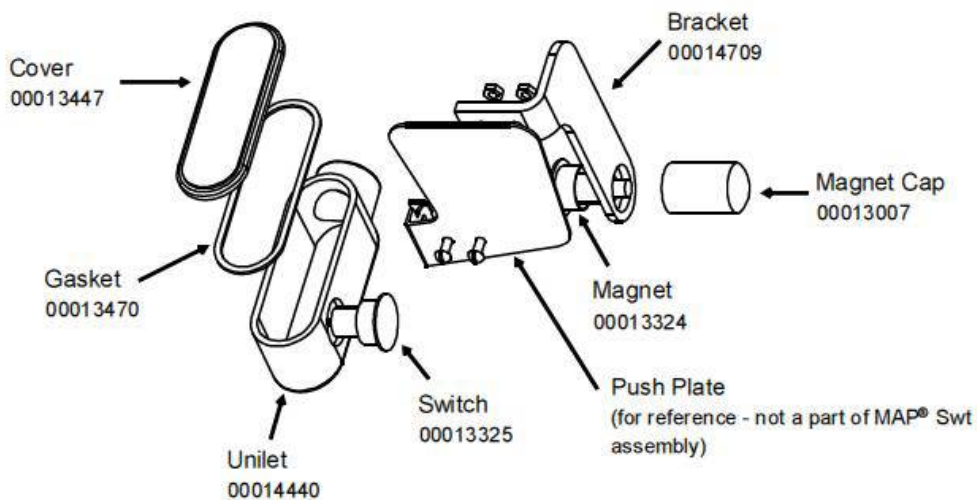

MAP® SWITCH ASSEMBLY – EYEWASH

Figure 7A. MAP SWITCH ASSEMBLIES

NOTE: MAP SWITCH
CAPACITY IS
20VA MAXIMUM.

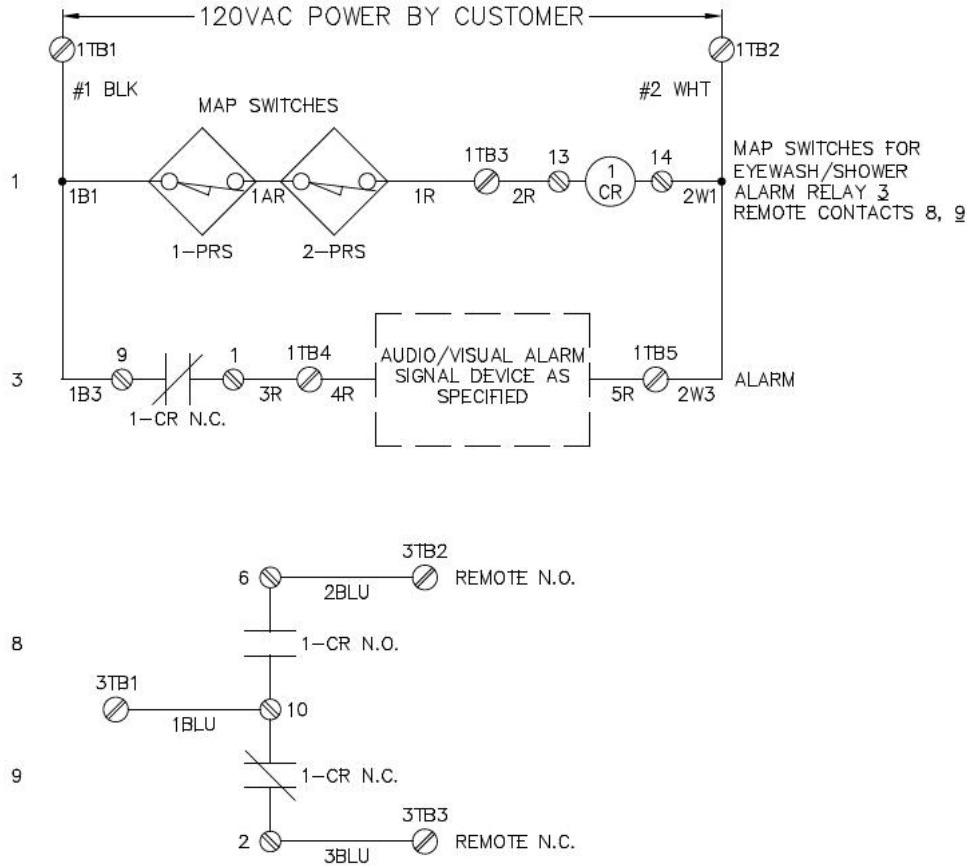

120 VAC shown for reference.

**Figure 7B. MAP® SWITCH
SCHEMATIC**

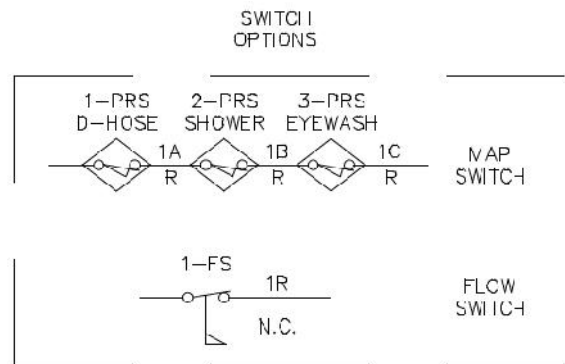
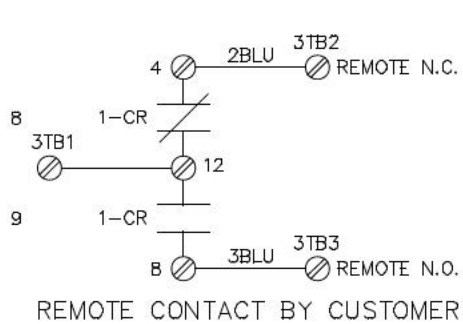
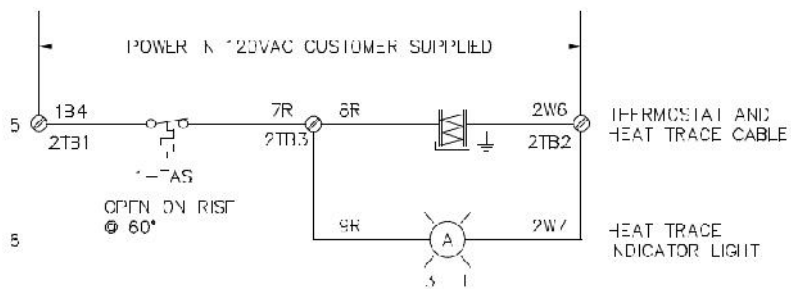
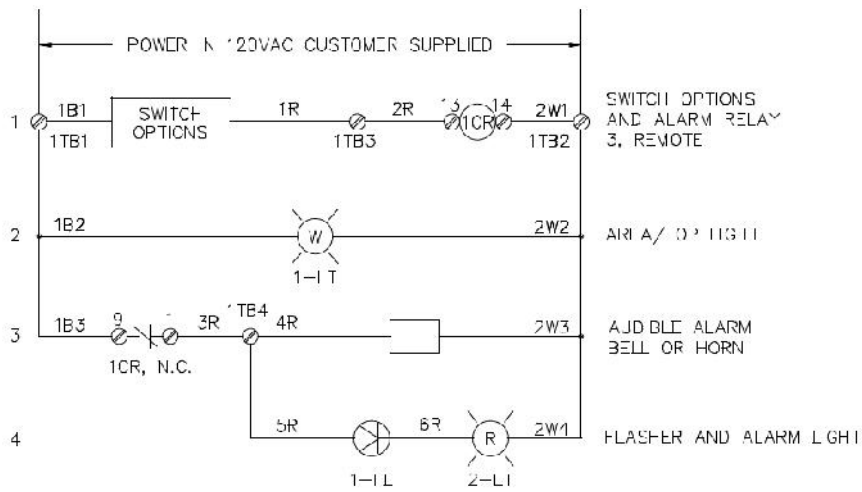

Figure 8A. WIRING DIAGRAM – 120 VOLT

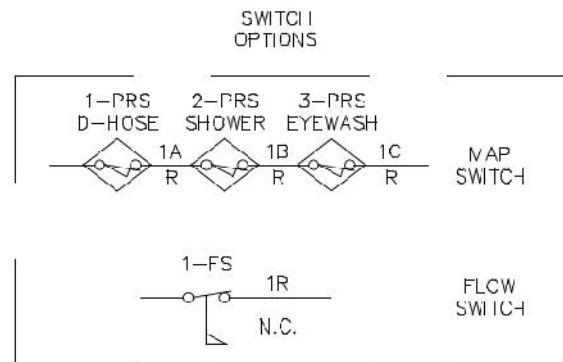
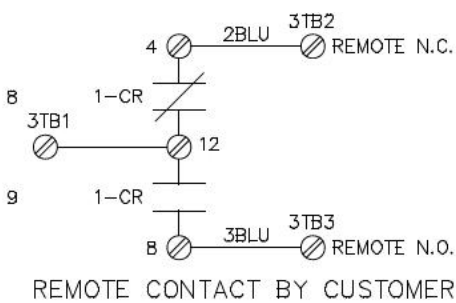
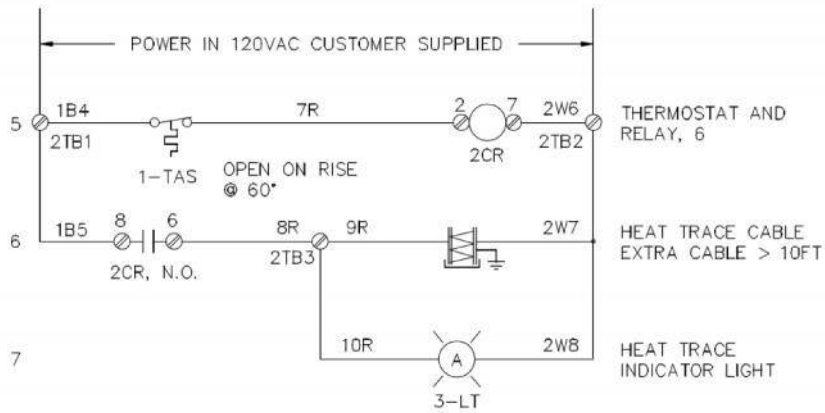
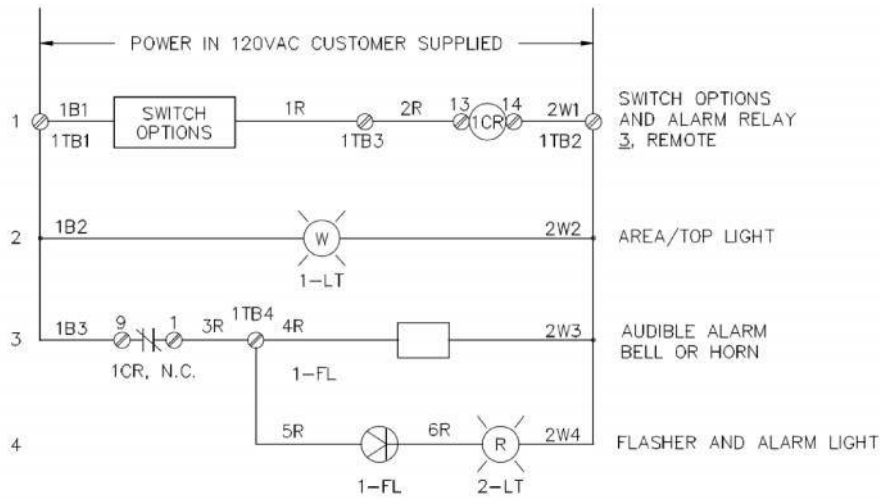

Figure 8B. WIRING DIAGRAM – 120 VOLT w/ EXTRA HEAT TRACE CABLE

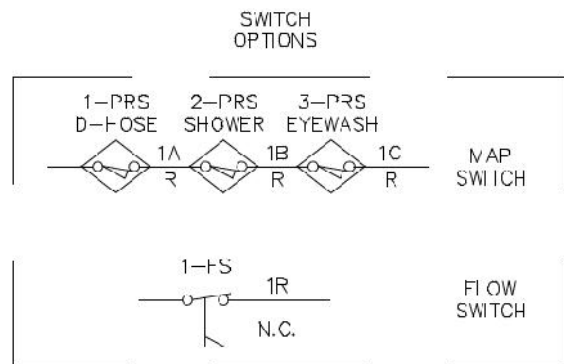
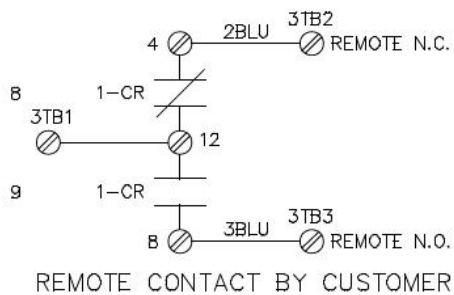
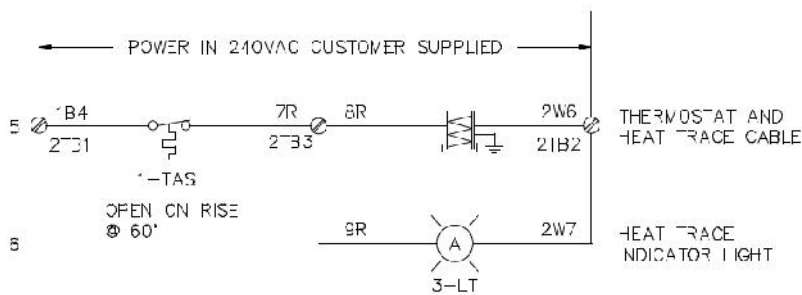
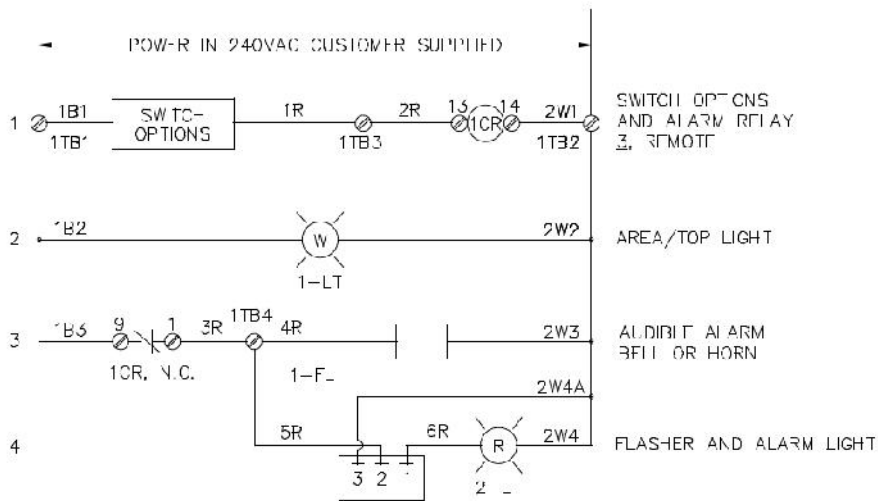
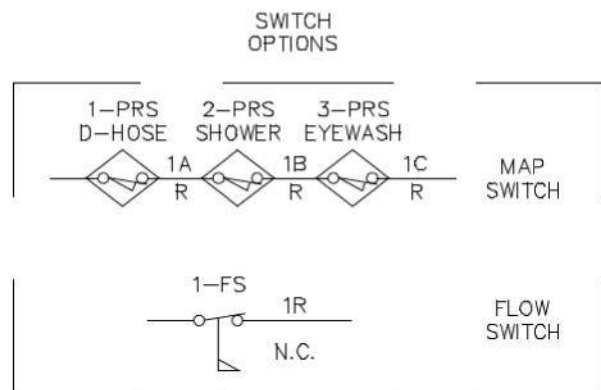
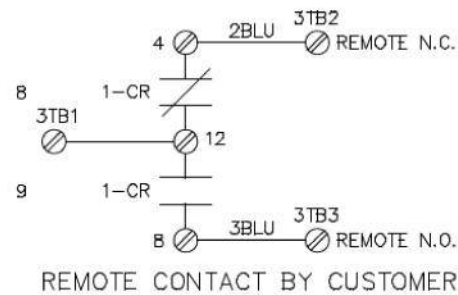
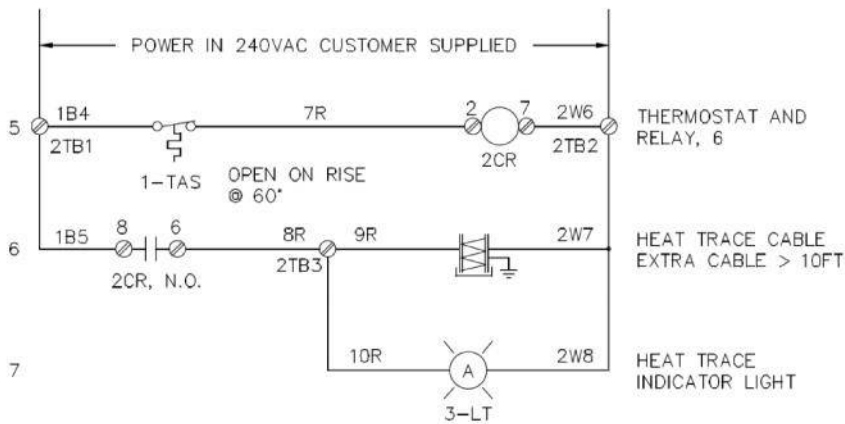
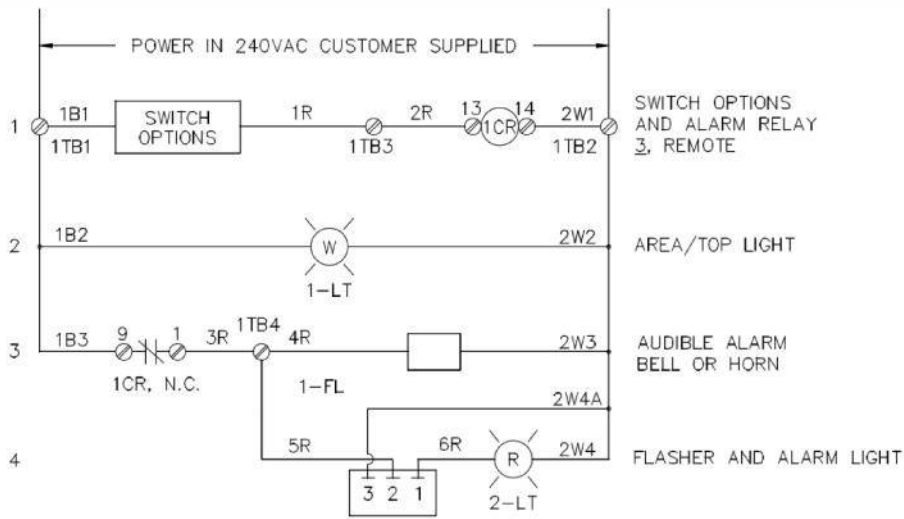
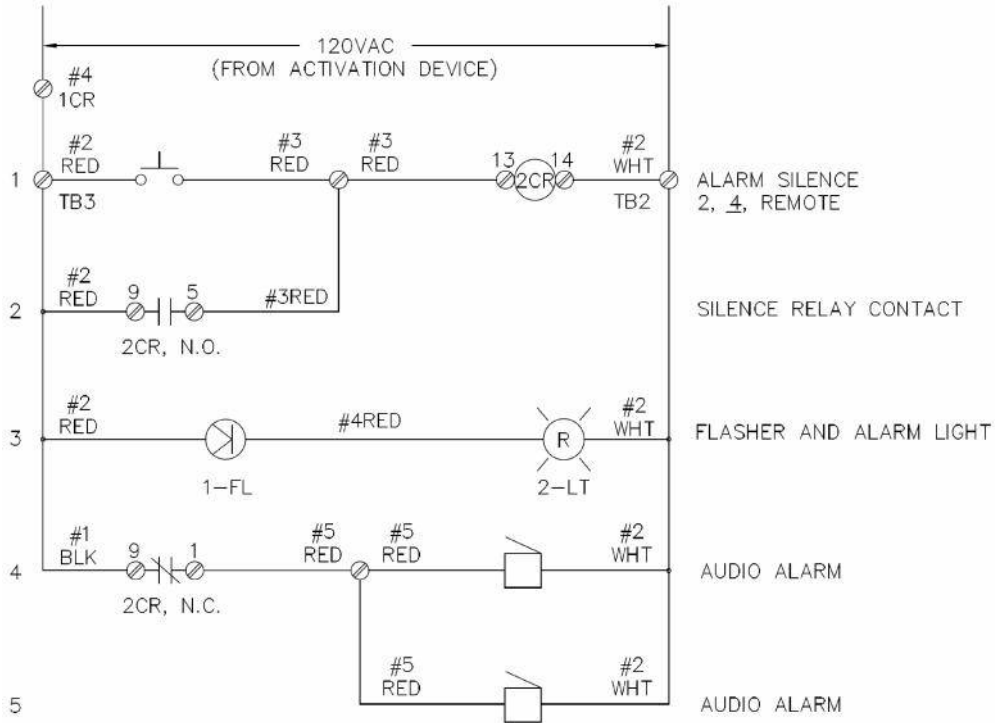

Figure 8C. WIRING DIAGRAM – 240 VOLT



**Figure 8D. WIRING DIAGRAM – 240 VOLT
w/ EXTRA HEAT TRACE CABLE**

PULSE TONE AUDIBLE ALARM
W/ RESET BUTTON



120 VAC shown for reference.

**Figure 8E. WIRING DIAGRAM – PULSE TONE
AUDIBLE ALARM**

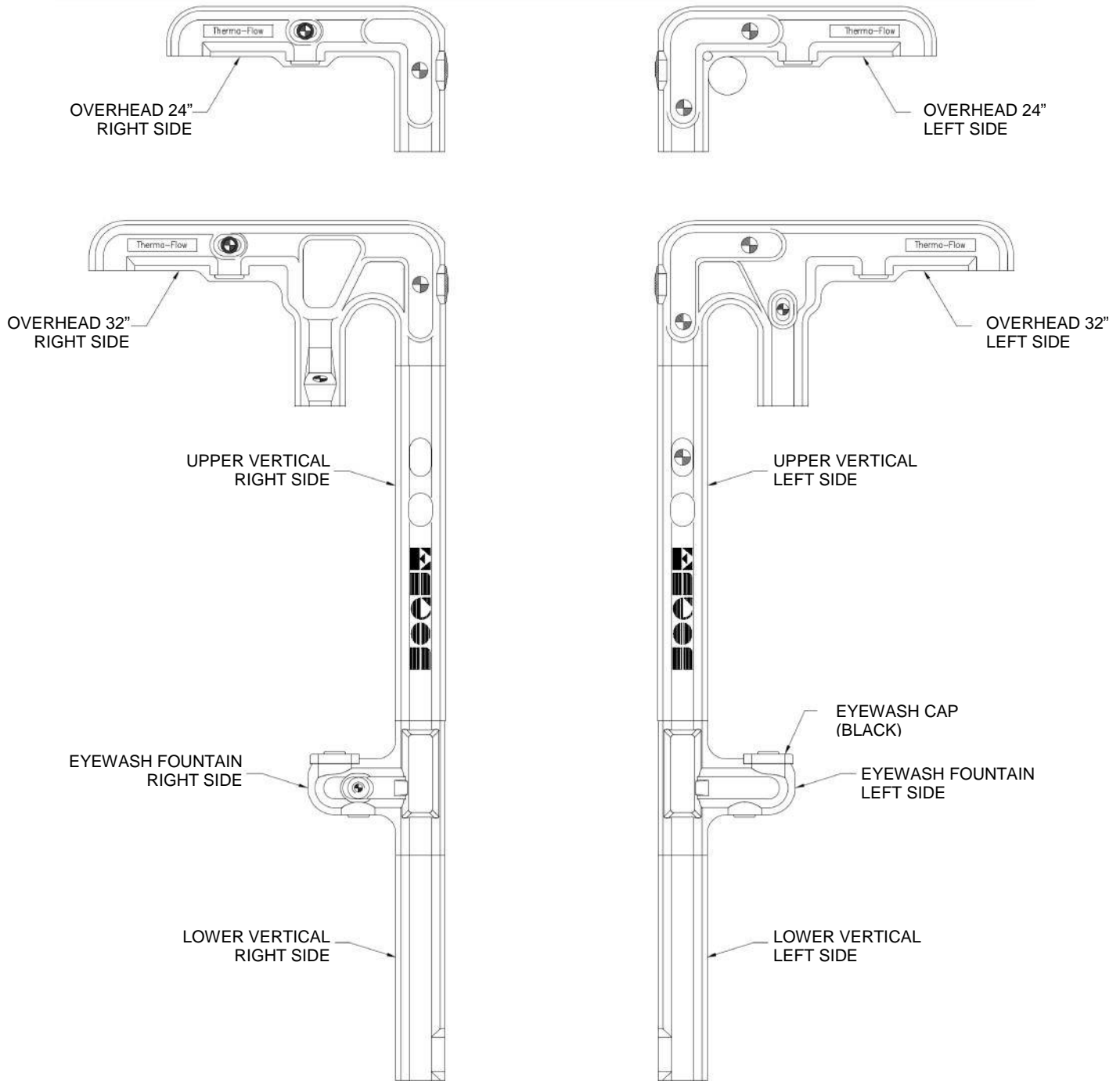
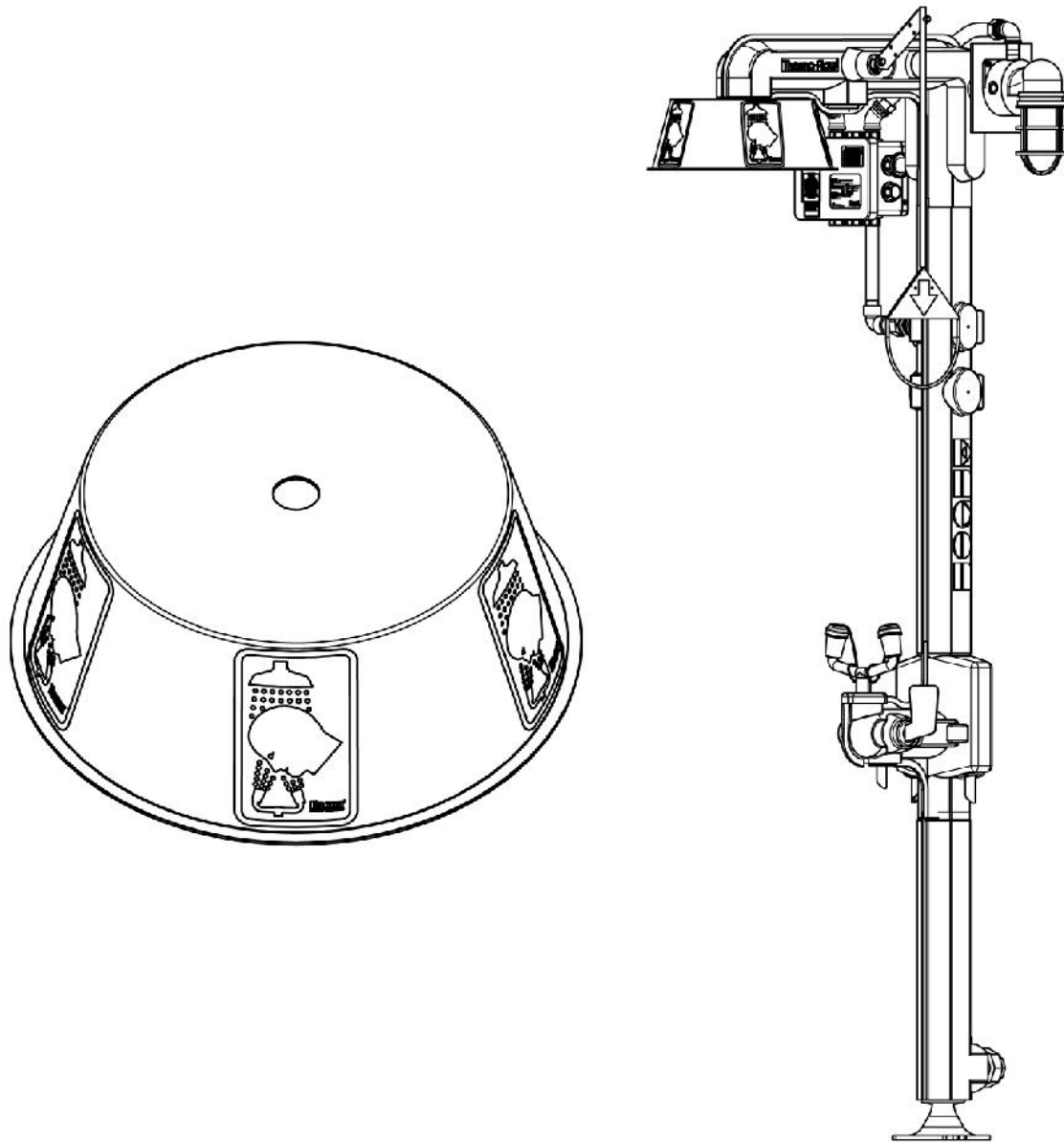

Figure 9. COVER ASSEMBLY

Figure 10. AWARENESS 360™ SIGN INSTALLATION INSTRUCTIONS

PART #: 35001810



INSTALLATION INSTRUCTIONS:

- 1) Remove the shower head from the piping.
- 2) Slide the sign onto the shower head piping using the hole provided in the top of the sign.
- 3) Screw the shower head back onto the piping and hand tighten securely.
- 4) Test the shower to check for interference.

Figure 11. EYEWASH BALL VALVE EXTENSION KIT INSTRUCTIONS

PART #: 01052515

P/N 01052515 – Ball Valve Extension Kit

1. Remove black seal strip from eyewash covers — SAVE.
2. Remove hex head bolt and push plate — DISCARD.
3. Remove eyewash covers — SAVE.
4. Remove grommet and valve extension, and unscrew the valve stop retainer — DISCARD.
5. Locate (#4) valve stop on (#3) valve stem assuring stop fits between (#2) fixed stops of valve at the 3 and 6 o'clock position.
6. Screw (#5) valve stop retainer on to (#3) valve stem.
7. Slide (#6) valve extension over (#5) valve stop retainer, locking (#6) valve extension on to (#4) valve stop.
8. Insert (#8) valve extension grommet into cover.
9. Slip (#7) eyewash cover over (#6) valve extension.
10. Place (#9) push plate over (#5) valve stop retainer and secure by;
11. Attaching (#10) bolt thru (#9) push plate, into (#5) valve stop retainer.
12. Replace existing black seal strip to covers.
13. Test valve operation by assuring push plate is at 12 o'clock when valve is off.

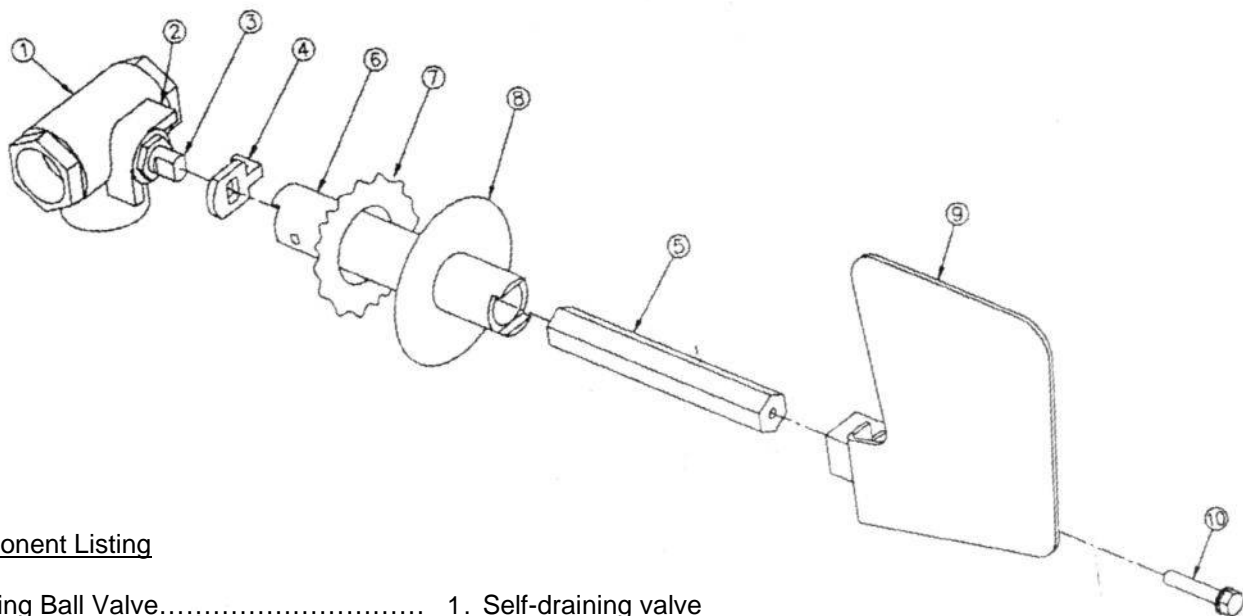

Component Listing

*Existing Ball Valve.....	1. Self-draining valve
	2. Valve stop-fixed
	3. Valve stem
01-1101-42.....	4. Valve stop
	5. Valve stop retainer
	6. Valve extension
*Existing Cover.....	7. Eyewash cover
00-0136-64.....	8. Extension Grommet
01-0520-16.....	9. Push plate
00-0128-52.....	10. Hex bolt

*Existing parts are not included in kit P/N 01052515.

Consult factory for details on the following retrofit kits:

P/N 01052514 – Ball Valve Extension Kit w/ eyewash cover

P/N 01052513 – Ball Valve Extension Kit w/ eyewash cover and grommet for freeze protection valve

P/N 01052510 – Ball Valve Extension Kit w/ eyewash cover and freeze protection valve assembly

Figure 12. MAP[®] SWITCH REPAIR PARTS KIT FOR THERMA-FLOW[®]

- 1) Solvent weld (plex-weld) Cap (Item 2) over Magnet (Item 1) after insertion into Bracket. (Item 4)
- 2) 1" maximum clearance between Magnet and Switch when valve is off.
- 3) Drill 1" hole & RTV Switch (Item 3) into place. Be certain seal is watertight.

* Drench Hose not pictured below.

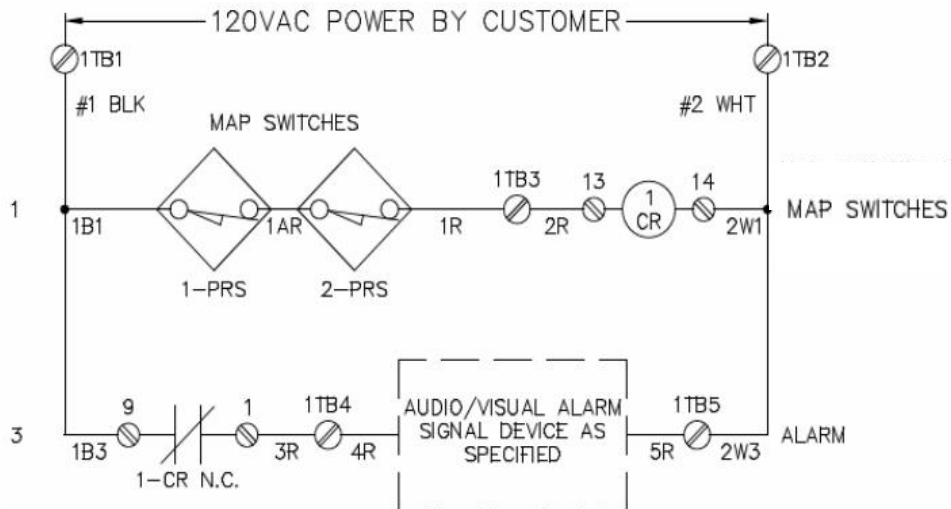
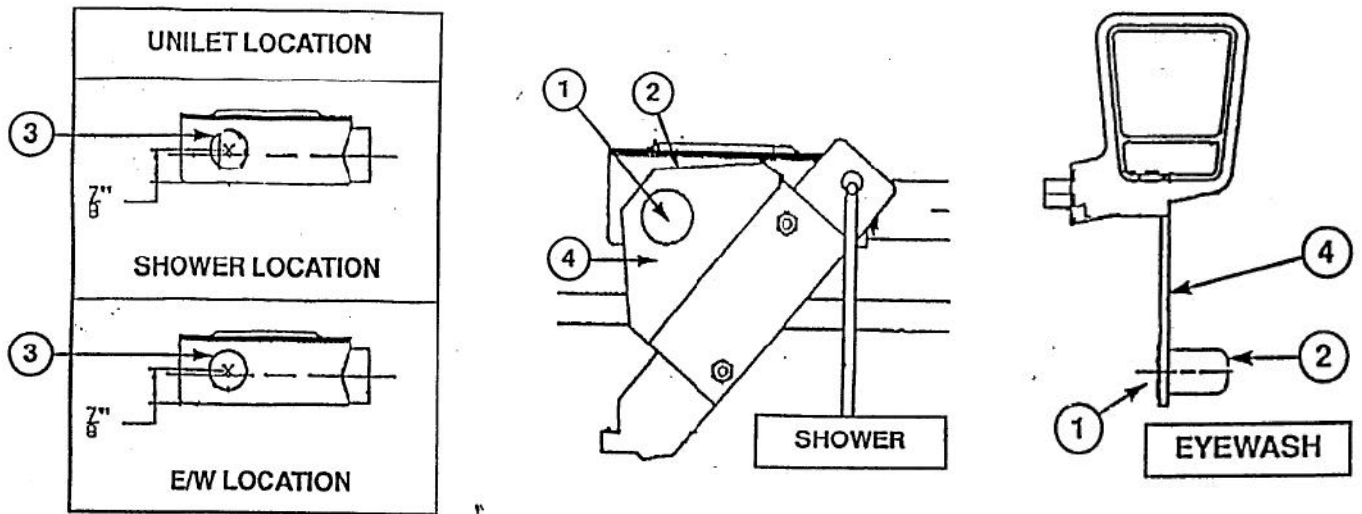

**SHOWER or DRENCH HOSE
MAP[®] SWITCH REPAIR PARTS KIT
01052326**

- 1) Magnet.....00013324
- 2) Magnet Cap.....00013007
- 3) Switch.....00013325
- 4) Bracket.....00014707

**EYEWASH
MAP[®] SWITCH REPAIR PARTS KIT
01052325**

- 1) Magnet.....00013324
- 2) Magnet Cap.....00013007
- 3) Switch.....00013325
- 4) Bracket.....00014709

PAGE LEFT BLANK INTENTIONALLY

DATE _____

AREA _____ MODEL NUMBER _____

TAG NUMBER _____ SERIAL NUMBER _____

I. VISUAL INSPECTION

	OK	NO
UNIT VISIBILITY		
AREA FREE OF DEBRIS (Within 10 seconds from hazard, Out of potential spray path)		
AREA LIGHT/ALARM LIGHT		
SIGN CONDITION		
EYEWASH COVERS ATTACHED AND IN PLACE ON NOZZLES		
SHOWER HEIGHT (Min. 82" – Max. 96" from standing level)		
EYEWASH HEIGHT (Min. 33" – Max. 45" from standing level, Min. 6" from nearest obstruction)		
VALVES (<input type="checkbox"/> Leaking: __Eyewash __Shower __Drench Hose)		
ACTUATORS EASILY LOCATED AND READILY IDENTIFIABLE		
PULL ROD NO GRATER THAN 69" FROM STANDING LEVEL		
INSULATION AND COVERS (<input type="checkbox"/> Adjustment <input type="checkbox"/> Replacement)		
HEAT TRACE INDICATOR LIGHT (<input type="checkbox"/> On <input type="checkbox"/> Off)		
FREEZE / SCALD PROTECTION VALVES (<input type="checkbox"/> Leaking: __F.P. Valve __S.P. Valve)		

II. OPERATIONAL INSPECTION

	OK	NO
SHOWER VOLUME (Min. 20 gpm)		
SHOWER PATTERN TEST (20" diameter pattern 60" from standing level)		
SHOWER VELOCITY, NONINJURIOUS TO USER (<input type="checkbox"/> Too High <input type="checkbox"/> OK)		
EYEWASH VOLUME (Min. 0.4 gpm)		
EYEWASH PATTERN TEST		
EYEWASH VELOCITY, NONINJURIOUS TO USER (<input type="checkbox"/> Too High <input type="checkbox"/> OK)		
STAY OPEN VALVES "OFF" TO "ON" IN ONE SECOND OR LESS		
COMPONENTS OPERATE SIMULTANEOUSLY TO ANSI REQUIRMENTS		
ALARM TEST Local: Shower <input type="checkbox"/> OK <input type="checkbox"/> No, Eyewash <input type="checkbox"/> OK <input type="checkbox"/> No Remote: Shower <input type="checkbox"/> OK <input type="checkbox"/> No, Eyewash <input type="checkbox"/> OK <input type="checkbox"/> No		
SUPPLY WATER PRESSURE (Min. 40 psi for 20 gpm models / 30 psi for 30 gpm models): _____		
WATER TEMPERATURE (78° TO 92°F): _____		

Comments: _____

Corrective action required to the shower/eyewash parts to place unit in operational readiness state:

Action required other than to the shower/eyewash parts to correct operation:

PAGE LEFT BLANK INTENTIONALLY

PAGE LEFT BLANK INTENTIONALLY



6825 W. Sam Houston Pkwy. N (77041)
P.O. Box 3826 • Houston, Texas (77253)
(713) 466-1449 • Fax (713) 466-1819
1-800-AT-ENCON / 1-800-283-6266
customerservice@enconsafety.com
<http://www.enconsafety.com>